

POGONSKI STROJEVI- MOTORI

Definicija: Pogonski strojevi pretvaraju određeni oblik energije iz prirode u mehaničku energiju koja služi za pogon radnih strojeva.

Podjela pogonskih strojeva

- Živi (animalni) pogonski strojevi
- Vodni (hidraulički) pogonski strojevi
- Vjetreni pogonski strojevi
- Toplinski pogonski strojevi
- Električni pogonski strojevi (elektro motori)

Živi (animalni) motori

- Radna stoka (konji, volovi, magarci, bivoli, mazge, mule...)
- Čovjek (ljudska radna snaga)

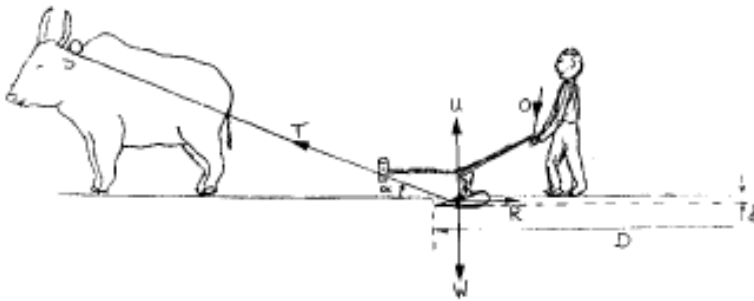
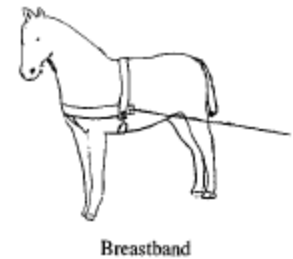
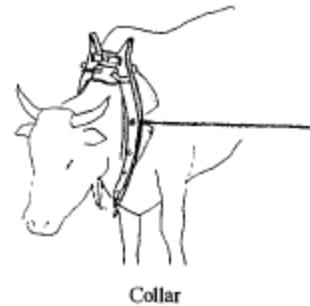

Vučna snaga različitih radnih životinja

Animal	Average Weight (kg)	Approximate Draught Capability (N)	Average Speed (m/s)	Power Developed (W)
Bullock	500–900	600–800	0.56–0.83	560
Cow	400–600	500–600	0.70	340
Water buffalo	400–900	500–800	0.80–0.90	560
Light horse	400–700	600–800	1.0	750
Mule	350–500	500–600	0.9–1.0	520
Donkey	200–300	300–400	0.70	260
Camel	450–500	400–500	1.1	500
Man	60–90	300	0.28	75

Hranidbene potrebe radnih volova

Table 7.4. Feed requirements for work oxen (adapted from FAO, 1972)

Weight of ox (kg)	Maintenance Ration (MJ)	Light Work		Medium Work		Heavy Work	
		Work Ration (MJ)	Total Ration (MJ)	Work Ration (MJ)	Total Ration (MJ)	Work Ration (MJ)	Total Ration (MJ)
250	29.9	15.6	45.5	29.9	59.8	45.5	75.4
300	33.8	16.9	50.7	33.8	67.6	50.7	84.5
350	37.7	19.5	57.2	37.7	75.4	57.2	94.9
400	41.6	20.8	62.4	41.6	83.2	62.4	104.0
450	45.5	23.4	68.9	45.5	91.0	68.9	114.4
500	49.4	24.7	74.1	49.4	98.8	74.1	123.5

Note. 1 kg of maize or other cereal grain yields about 13 MJ of metabolizable energy.

VODNI (HIDRAULIČKI) MOTORI

- Koriste potencijalnu i kinetičku energiju vode – vodna kola i vodne turbine

Peltonova turbina



Nadljevno vodno kolo

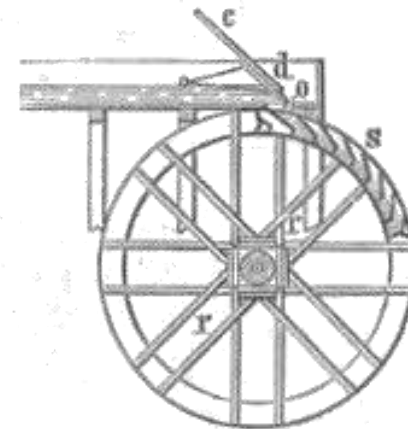

VJETRENI MOTORI

- Koriste kinetičku energiju strujanja zračnih masa.
- Služe za proizvodnju el. energije, crpljenje vode, pogon mlinova i sl.
- Danska proizvodi 10 % el. energije pomoću vjetrorenih turbina (do 2030. planiraju proizvoditi 50 % na taj način!)

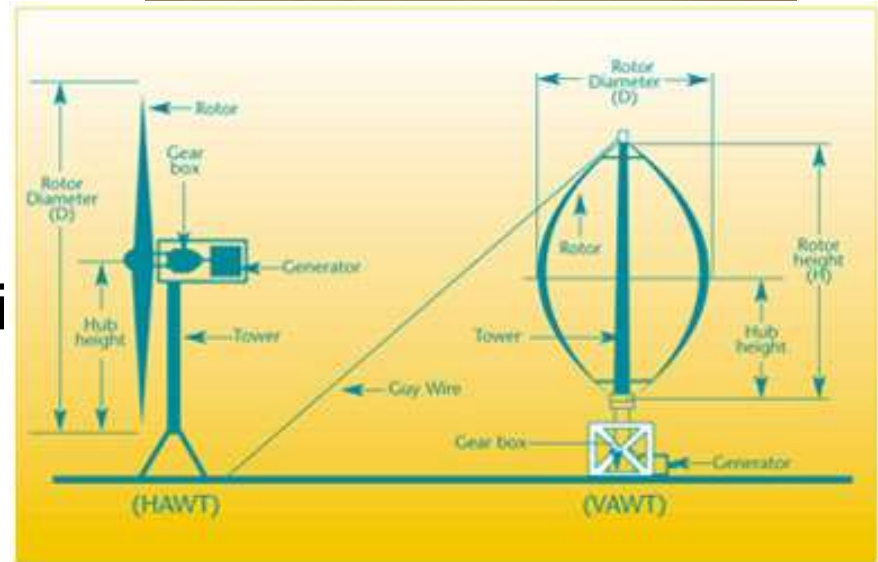

Nuklearna energija

- Reaktor nove generacije (reaktor, parna turbina, električni generator)

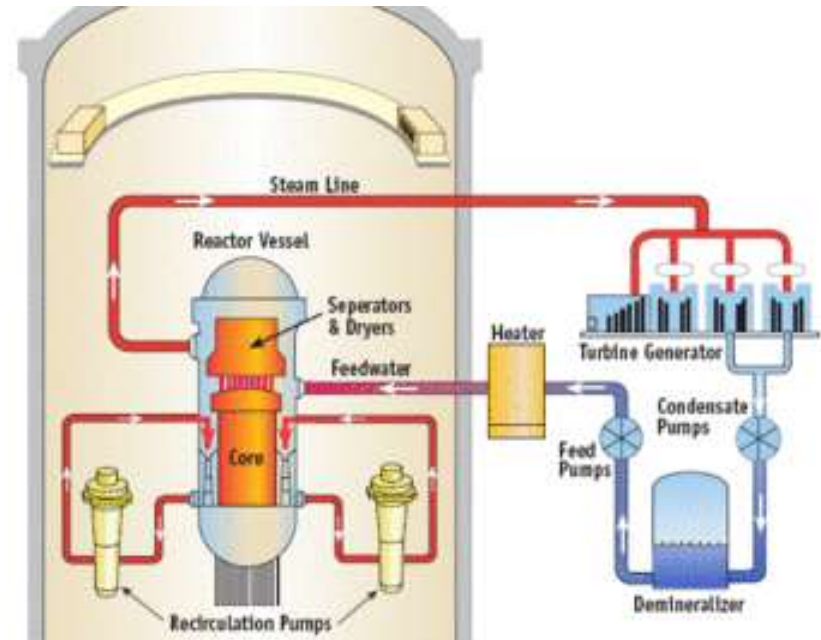

TOPLINSKI MOTORI

- Motori s vanjskim izgaranjem
 - Parna turbina
 - Stapni parni stroj
- Motori s unutrašnjim izgaranjem
 - Klipni motori SUI
 - Reaktivni motori SUI

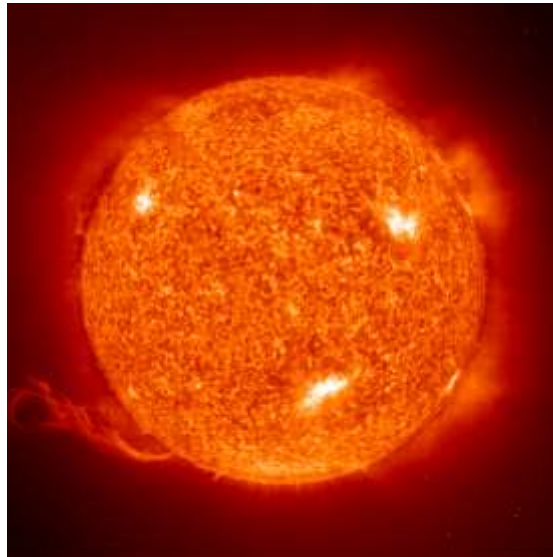

Motori s vanjskim izgaranjem

- Stapni parni stroj
(James Watt)

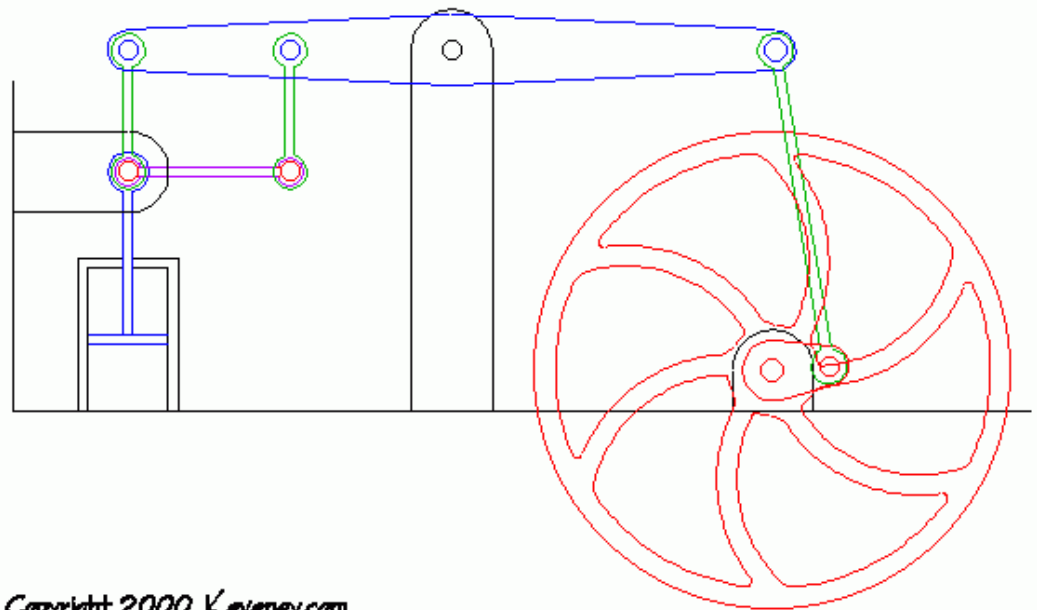

Copyright 2000, Keveney.com

Parni stroj lokomotive

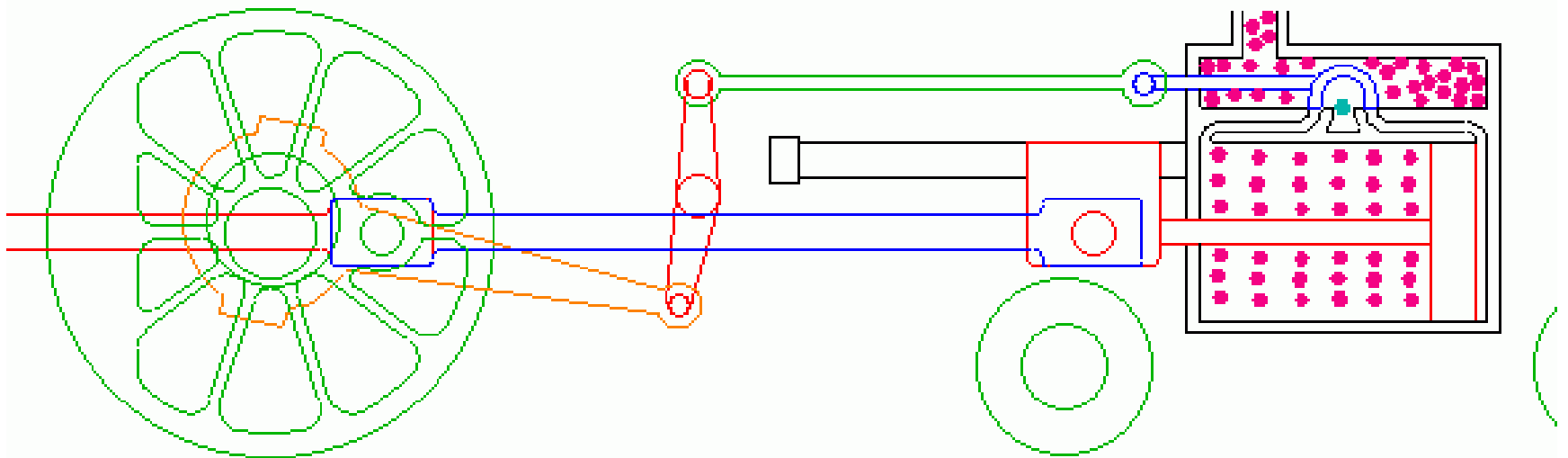

Copyright 2000, Kevoney.com

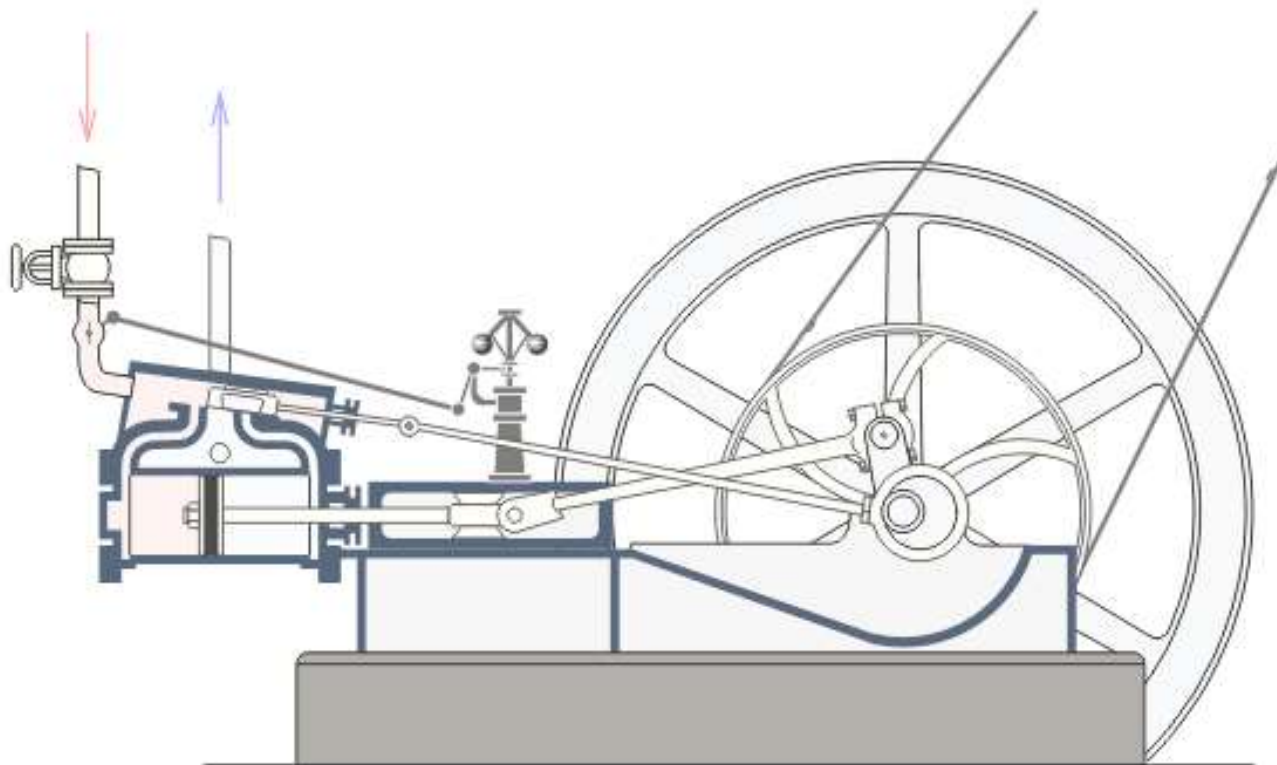

Turbinski motori – parna turbina

Parna turbina



Termoelektrana na ugljen

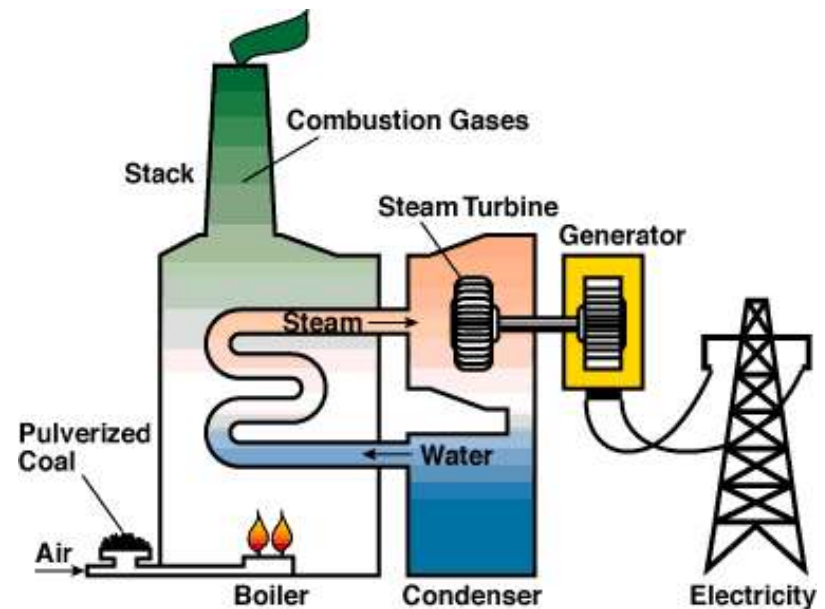

Klipni motori SUI

- 2-taktni klipni motori

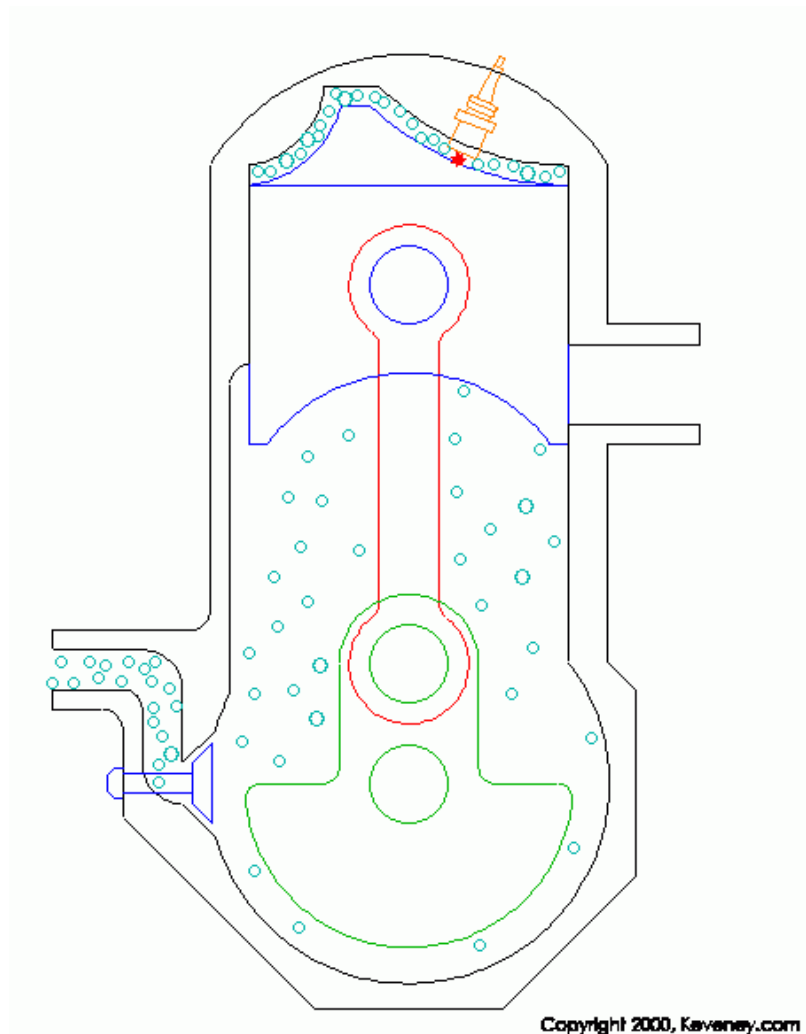

2-taktni motor

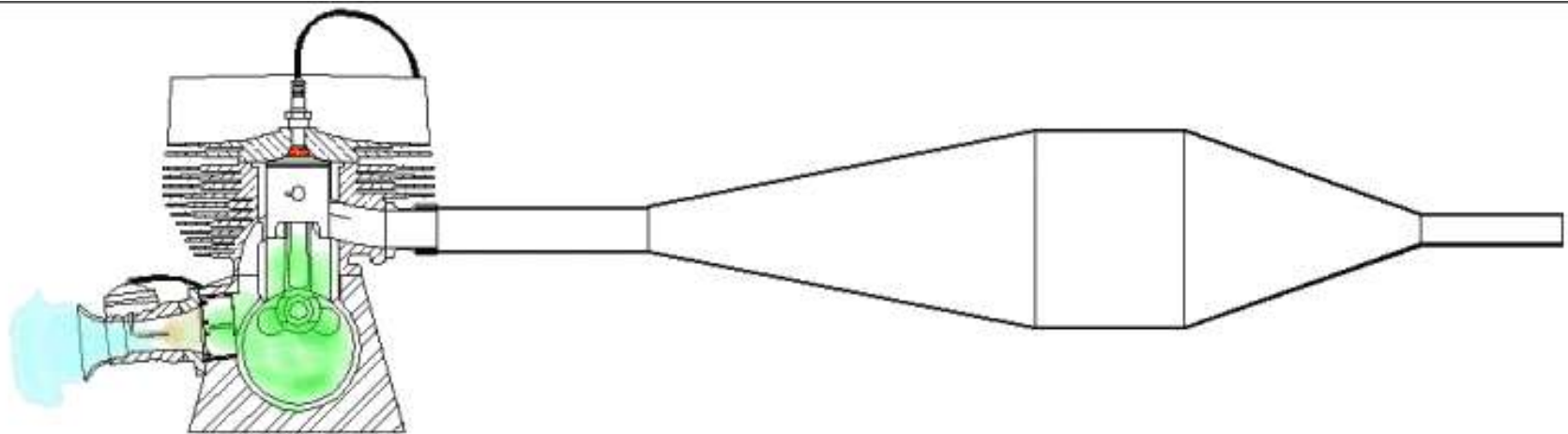

Klipni motori SUI

- 4-taktni klipni motori

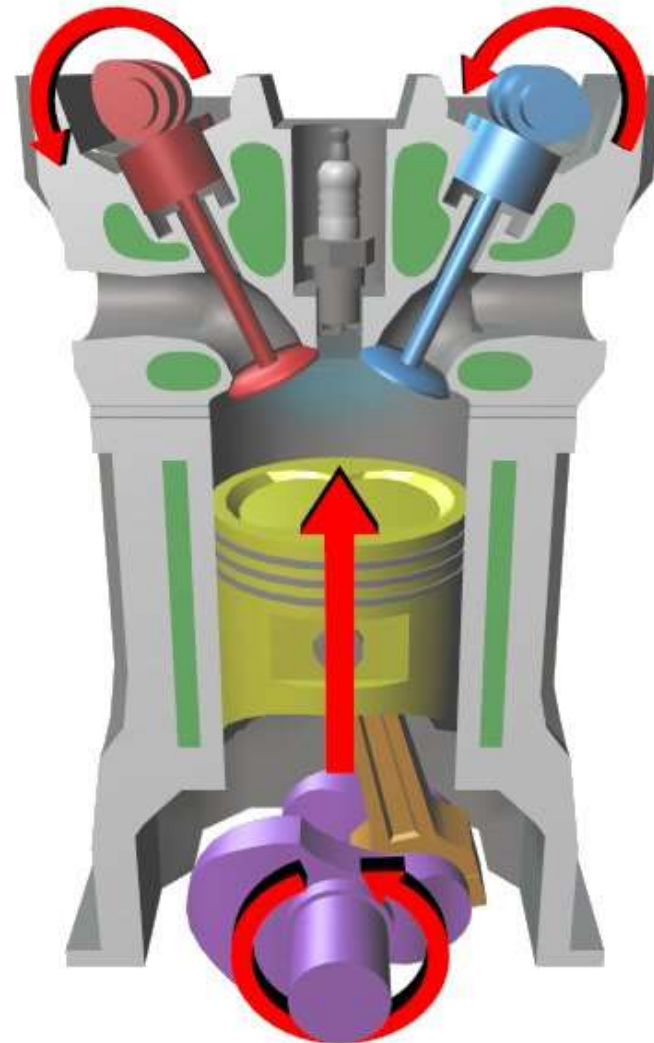

4-taktni Otto motor

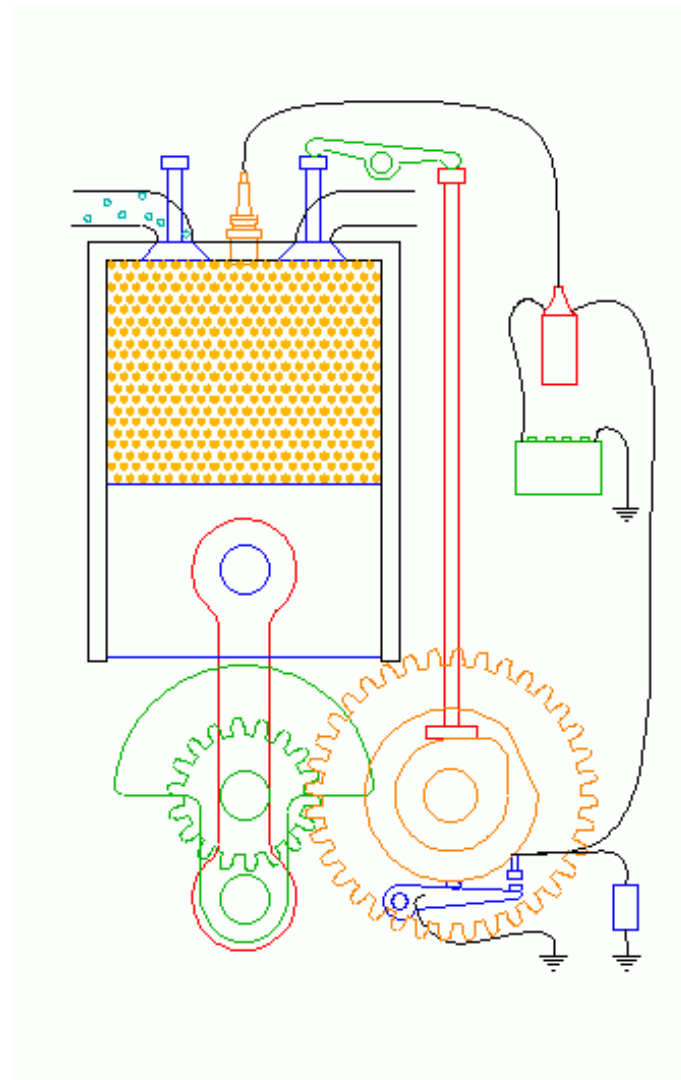

Indikatorski dijagram rada 4-taktnog Otto motora

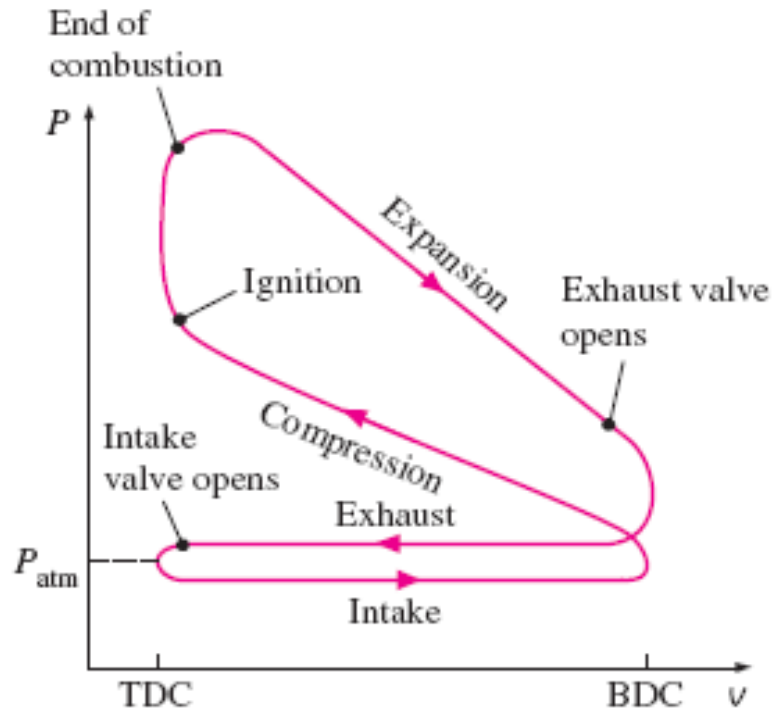

Princip rada 4-taktnog diesel motora

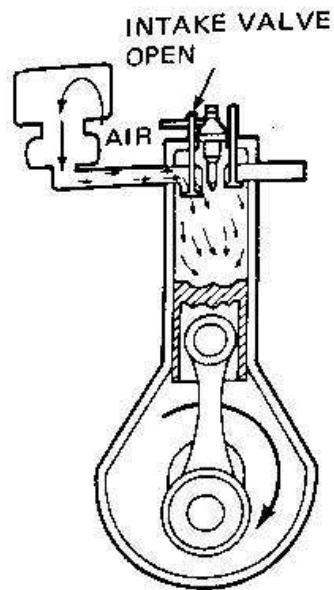

INTAKE

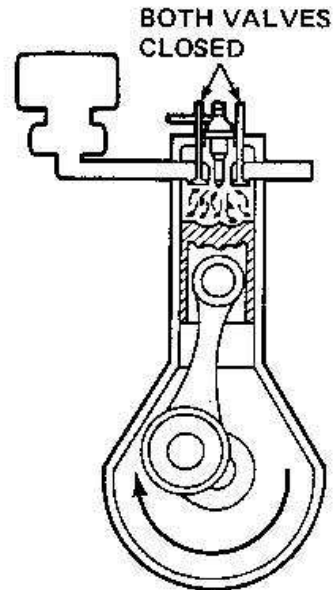

COMPRESSION

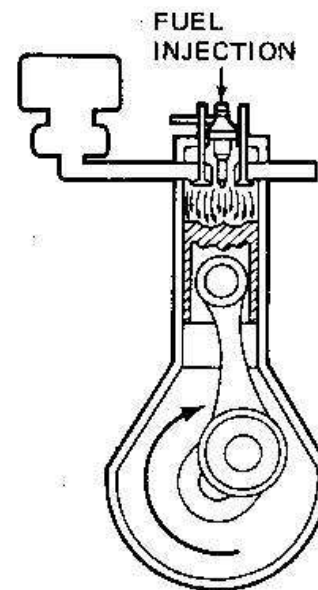

POWER

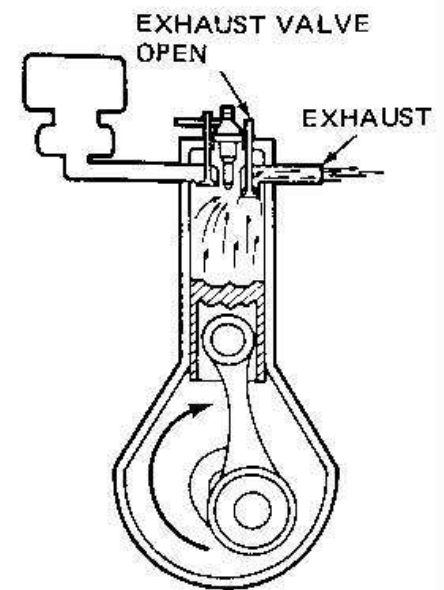

EXHAUST

Indikatorski dijagram rada 4-taktnog diesel motora

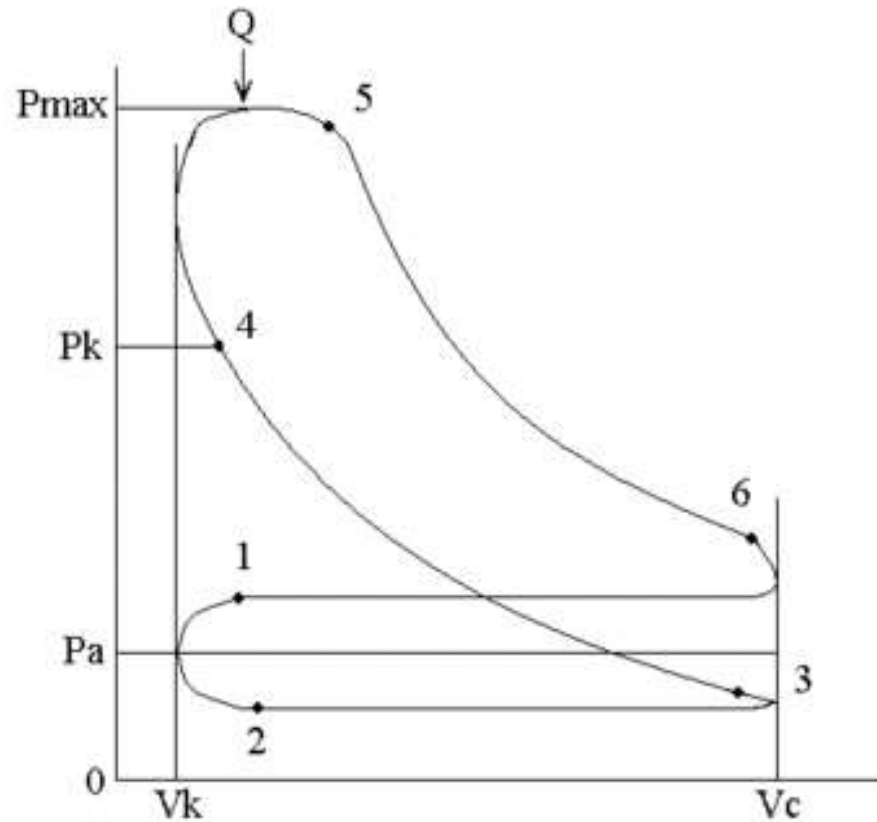

Princip rada 4-taktnog motora - animacija

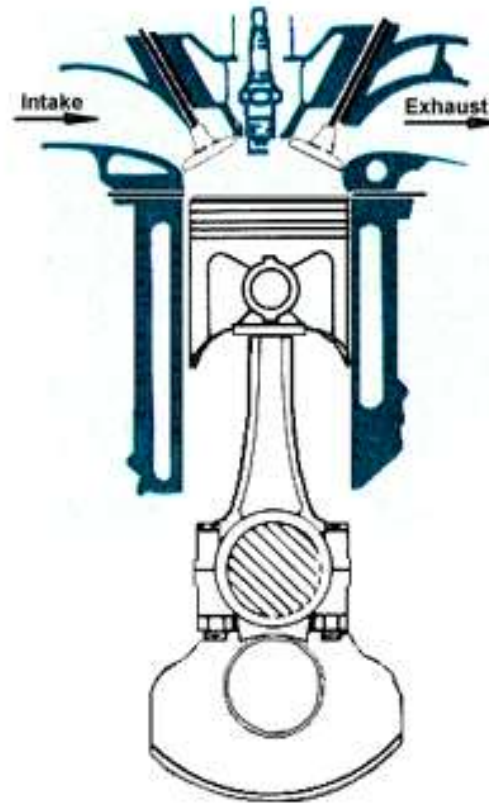

INTAKE

Redni motor

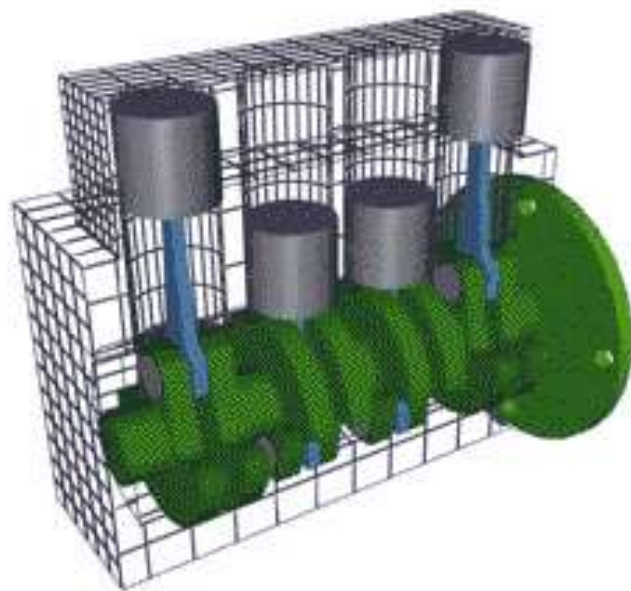

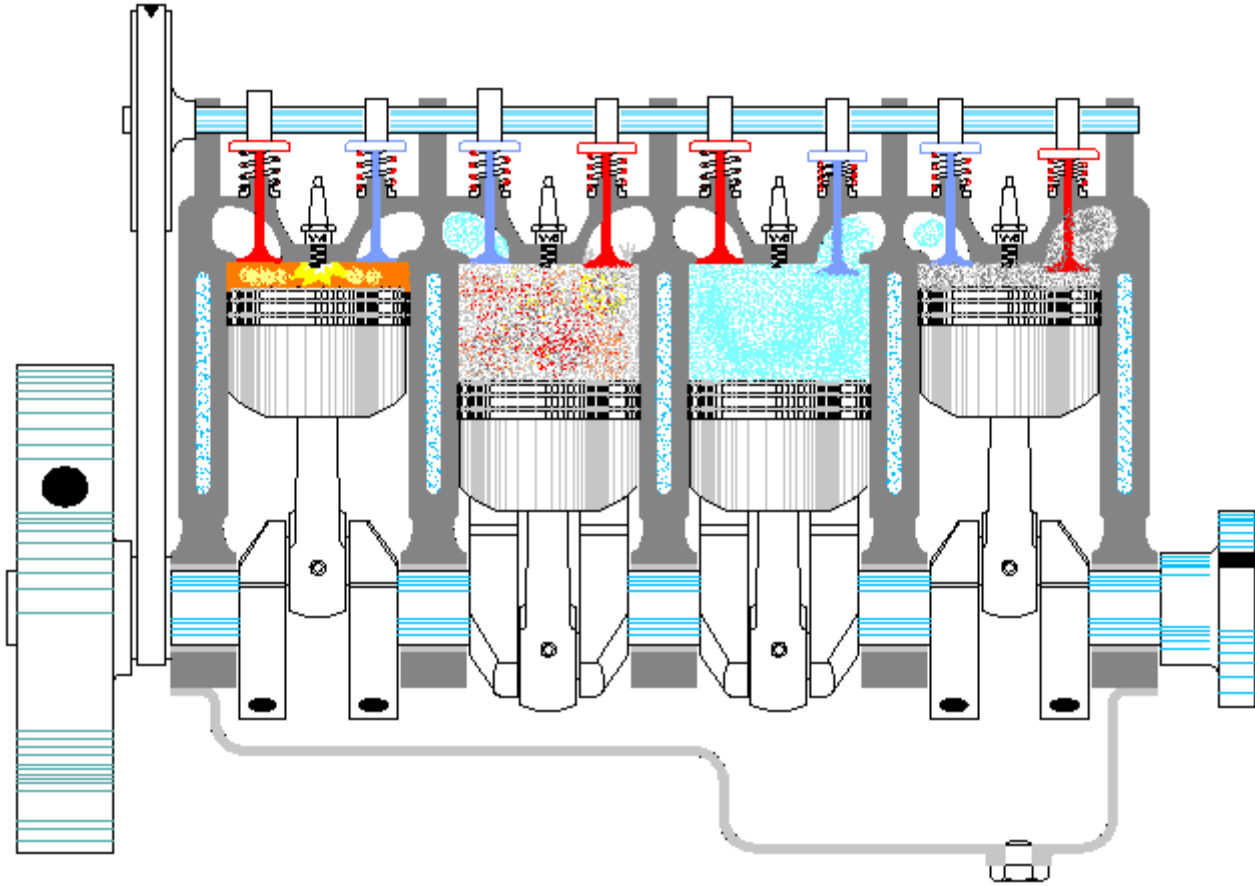

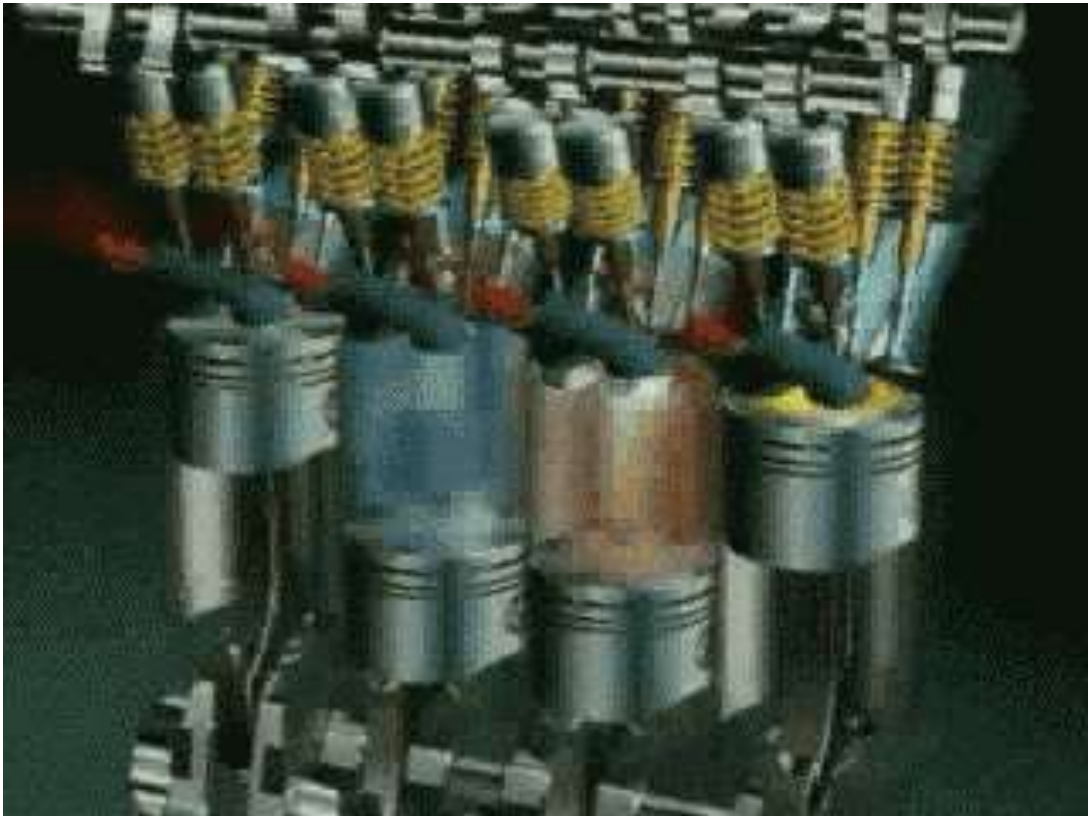

V - motor

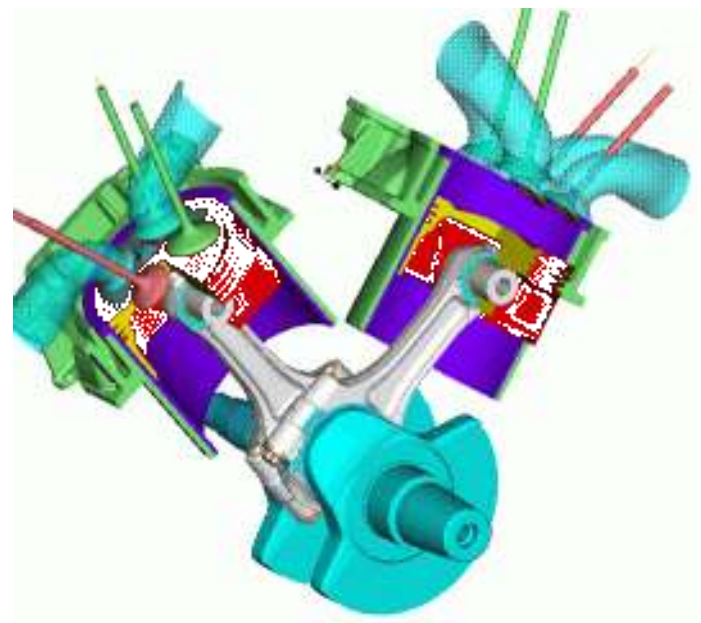
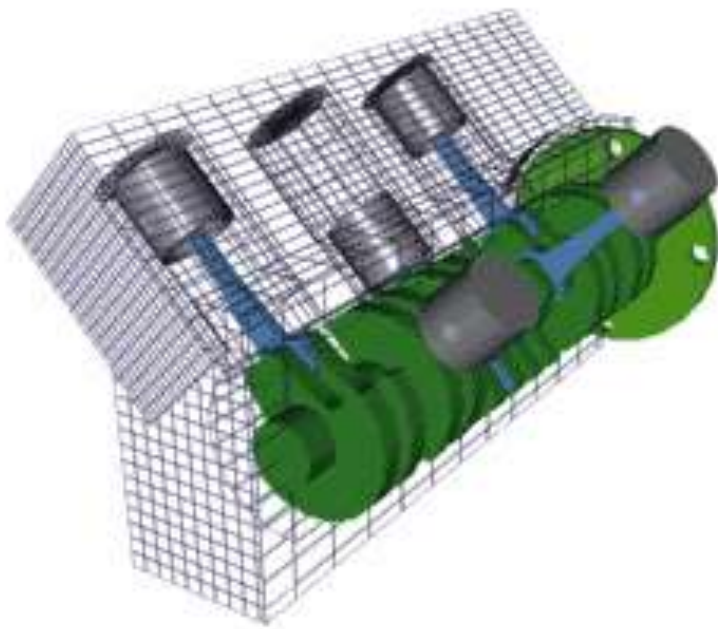

Boxer motor

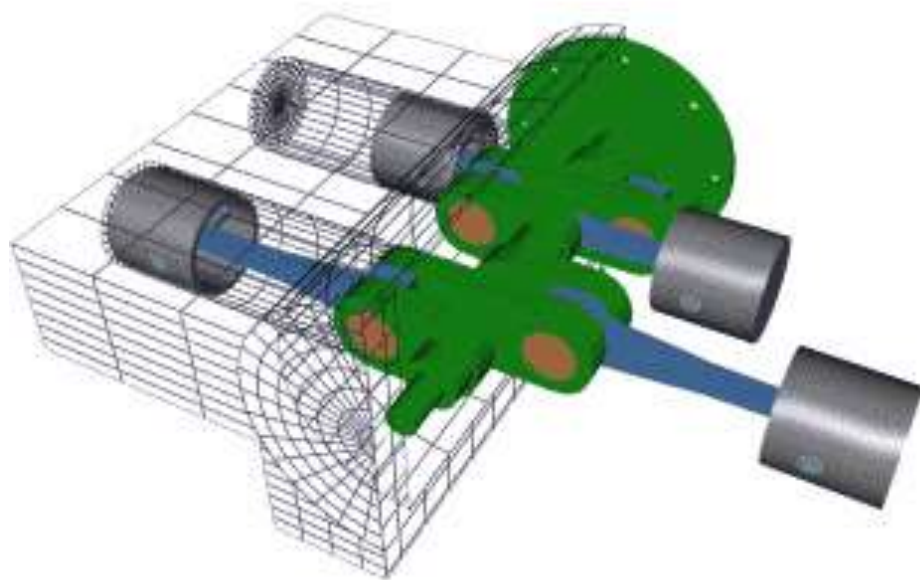

Motor s radijalnim klipovima

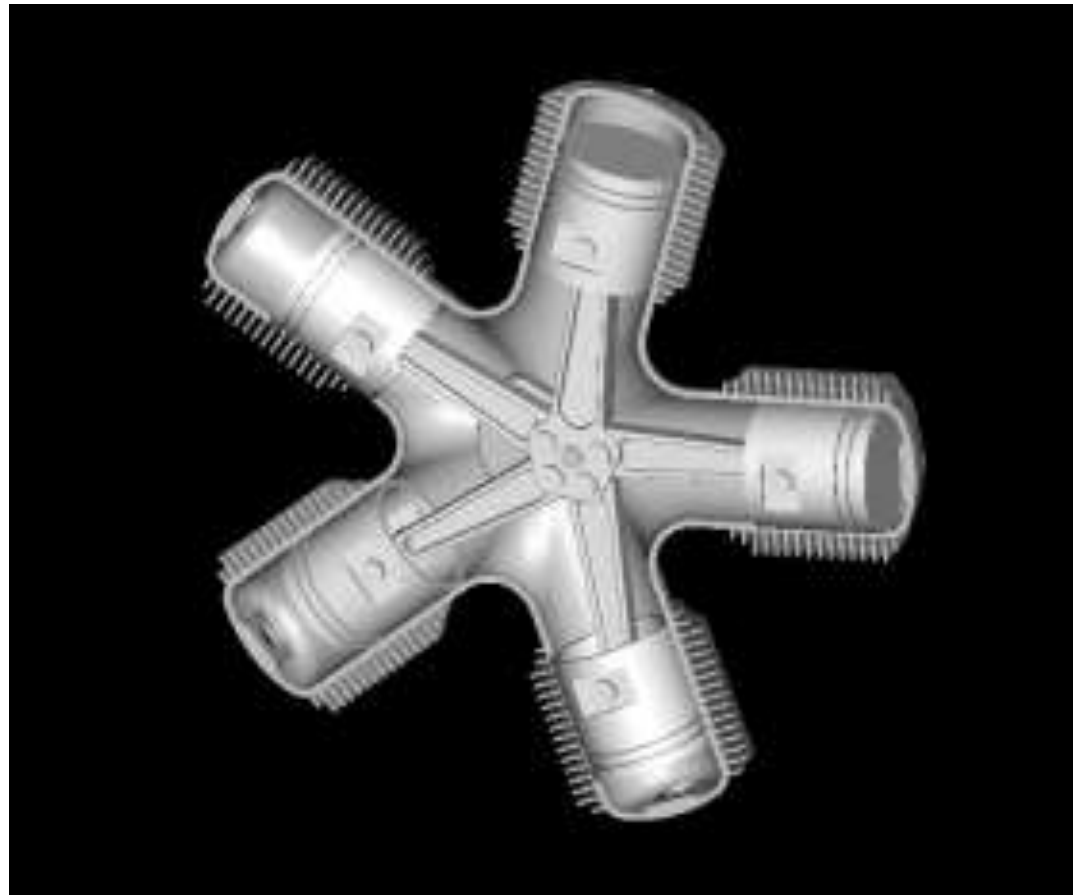

Wankelov motor

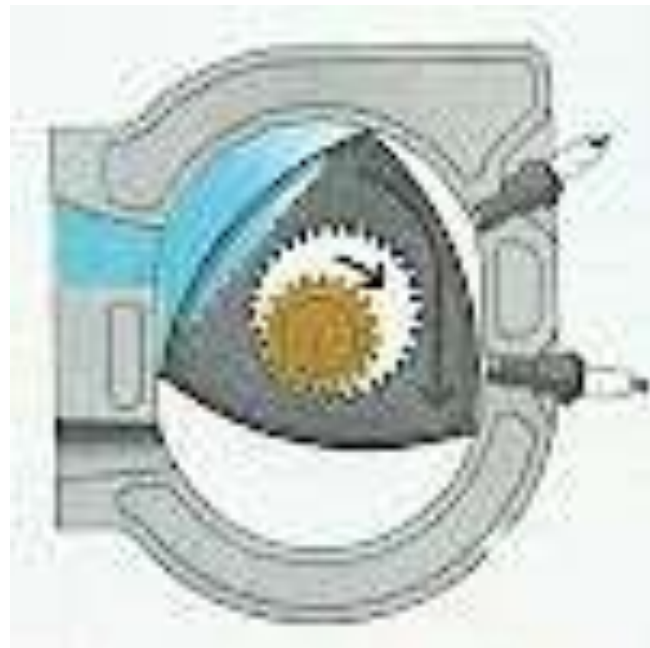

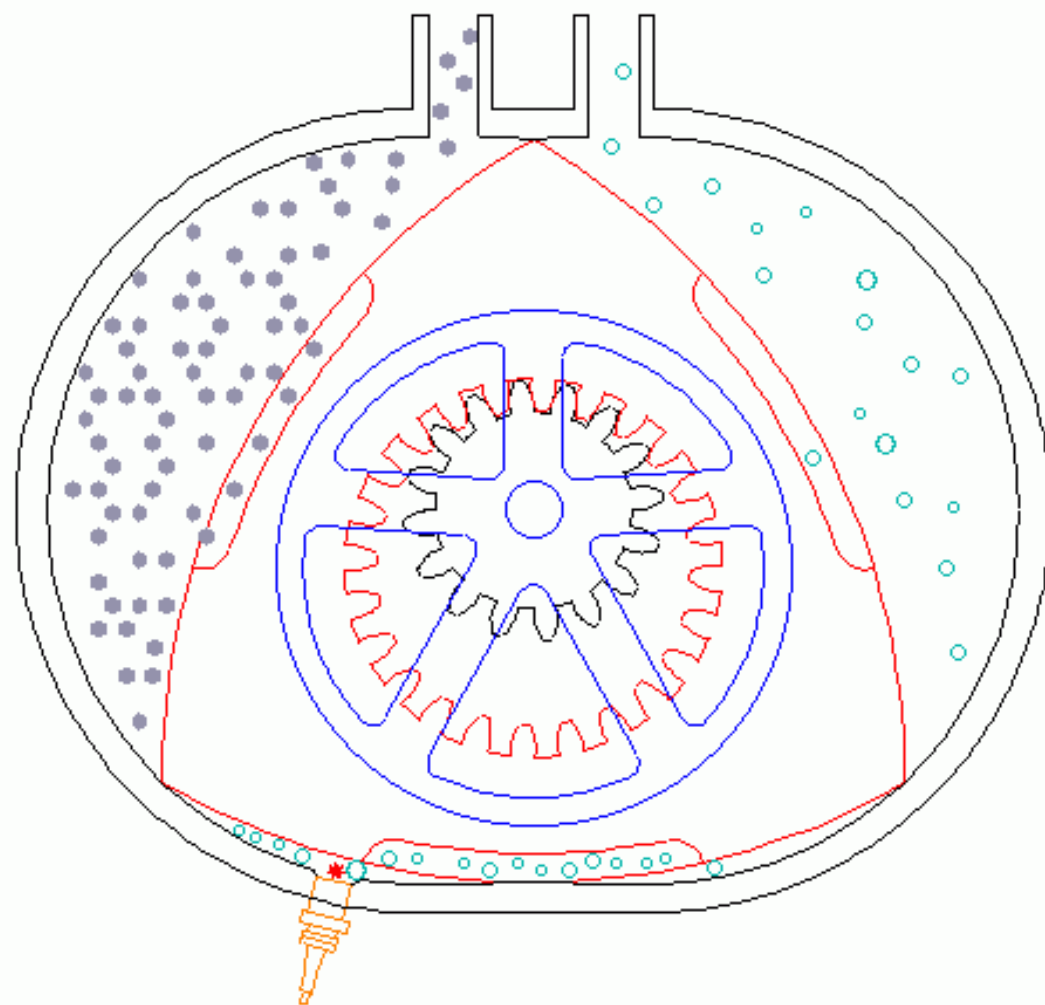

Copyright 2000, Keveney.com

Mlazni (reaktivni) motor

- S plinskom turbinom

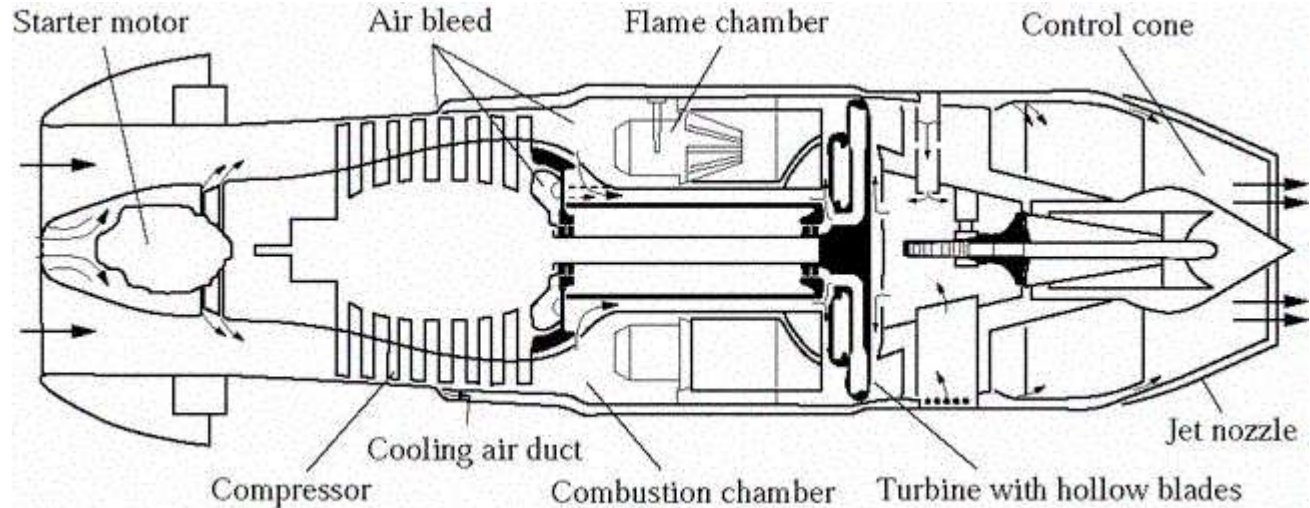
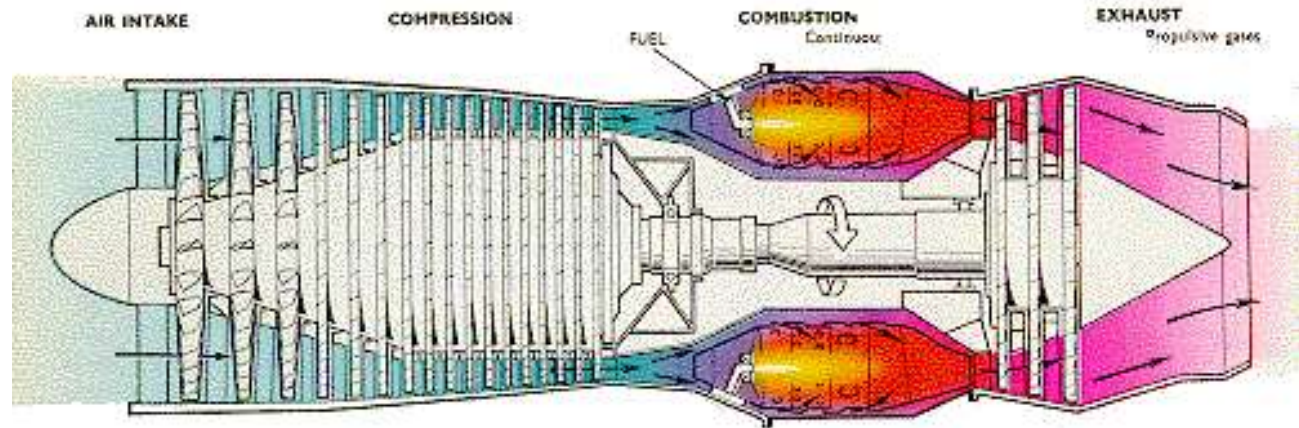

Mlazni motor

- Višestruka komora izgaranja

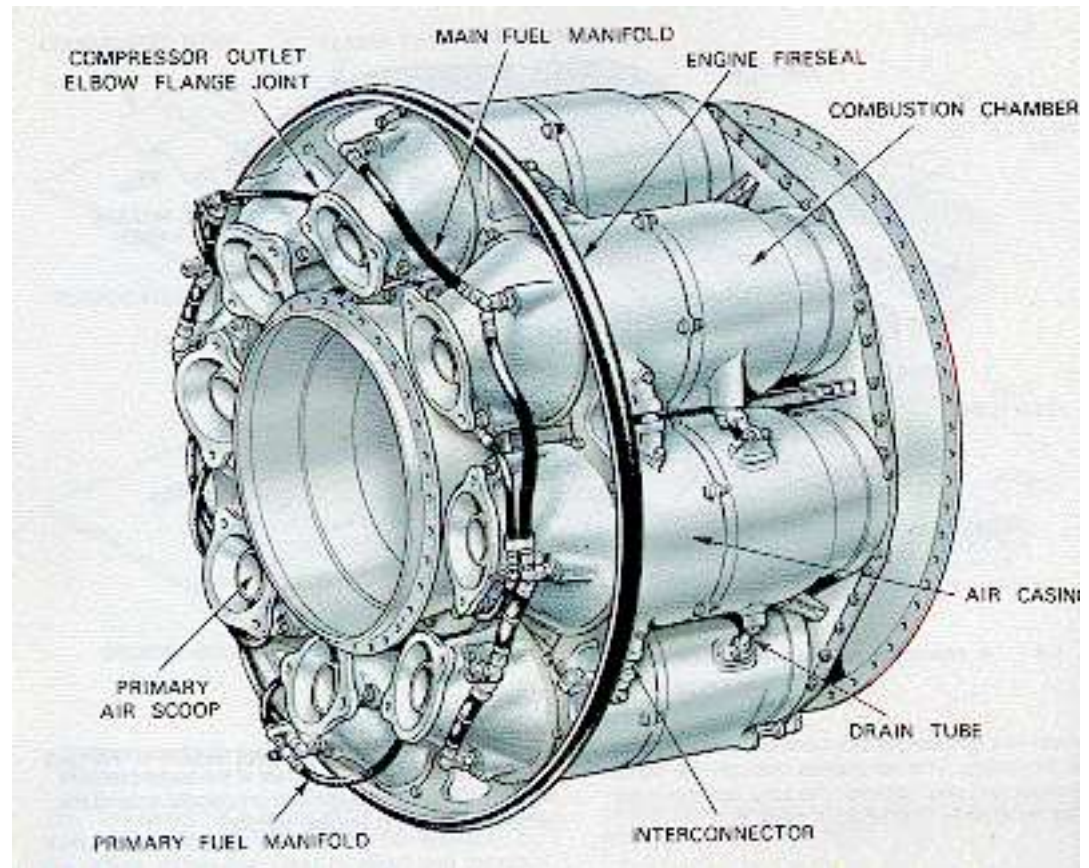

Mlazni motor (turbo jet)

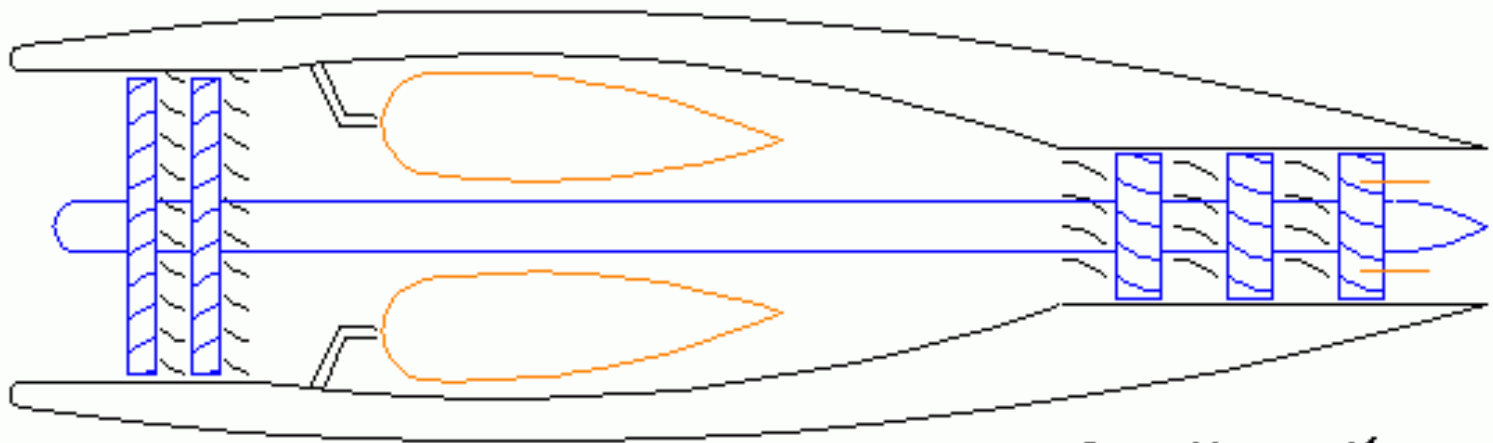

Copyright 2001, Keveney.com

Mlazni motor s elisom

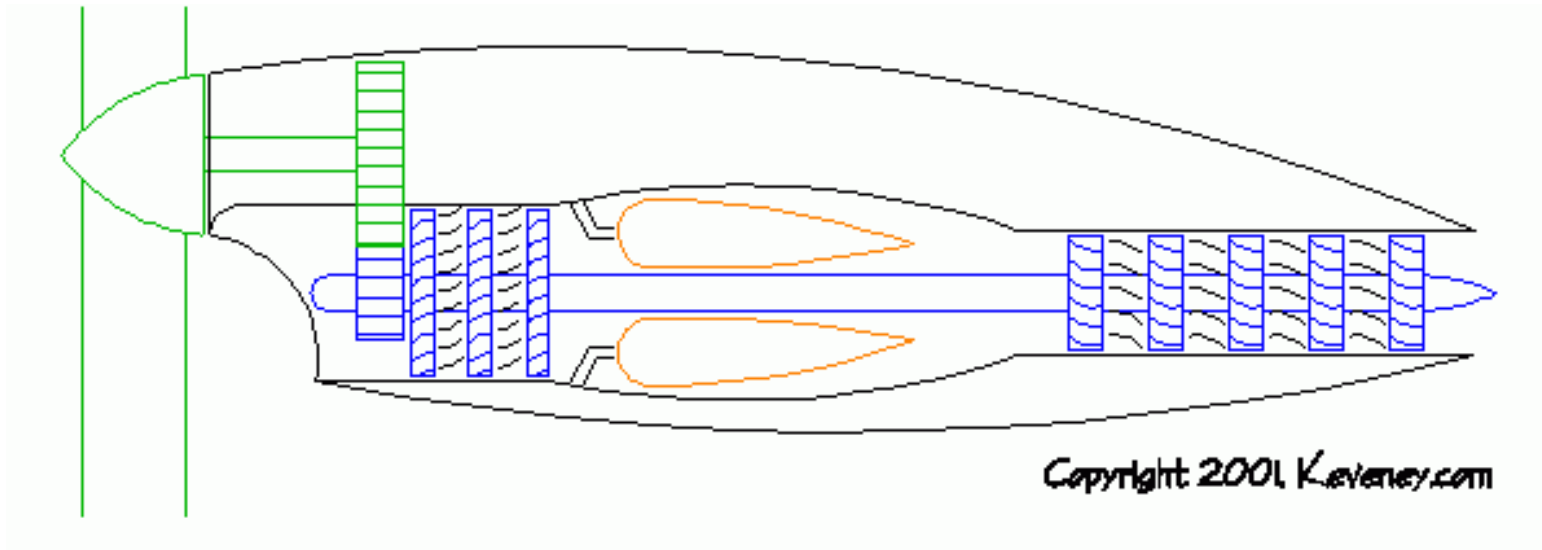

Mlazni motor s ventilatorom

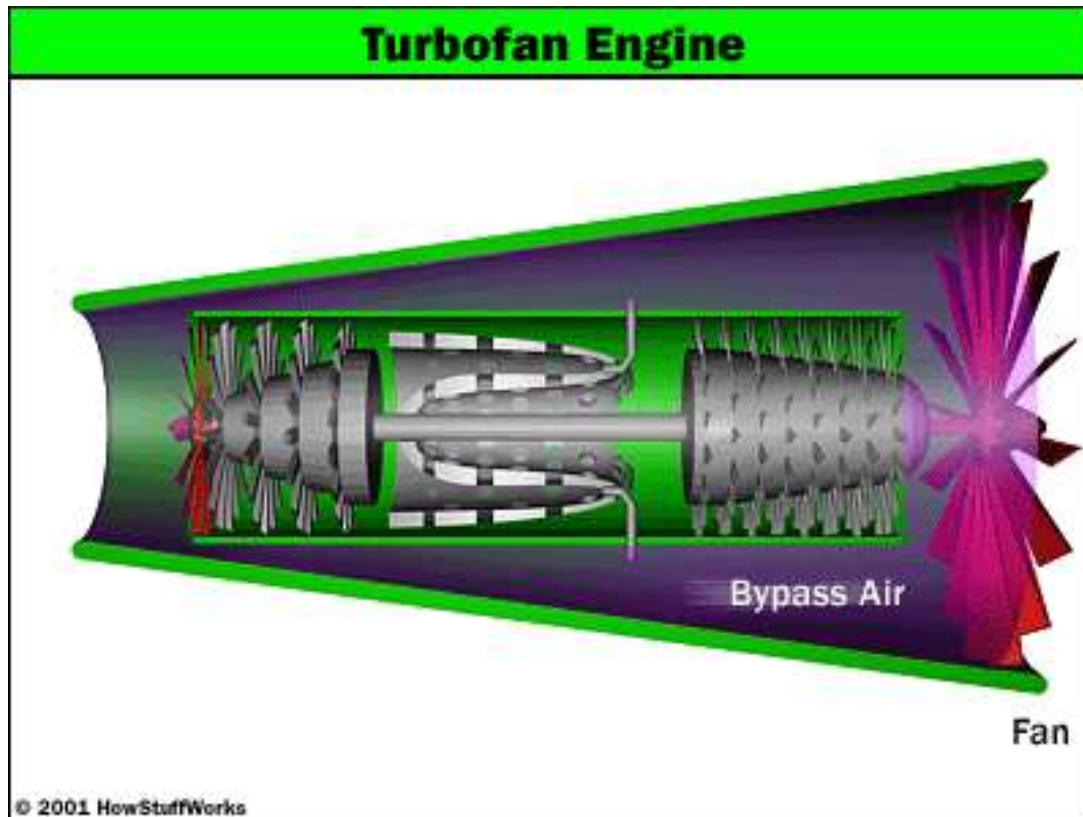

Turbo mlazni motor s ventilatorom

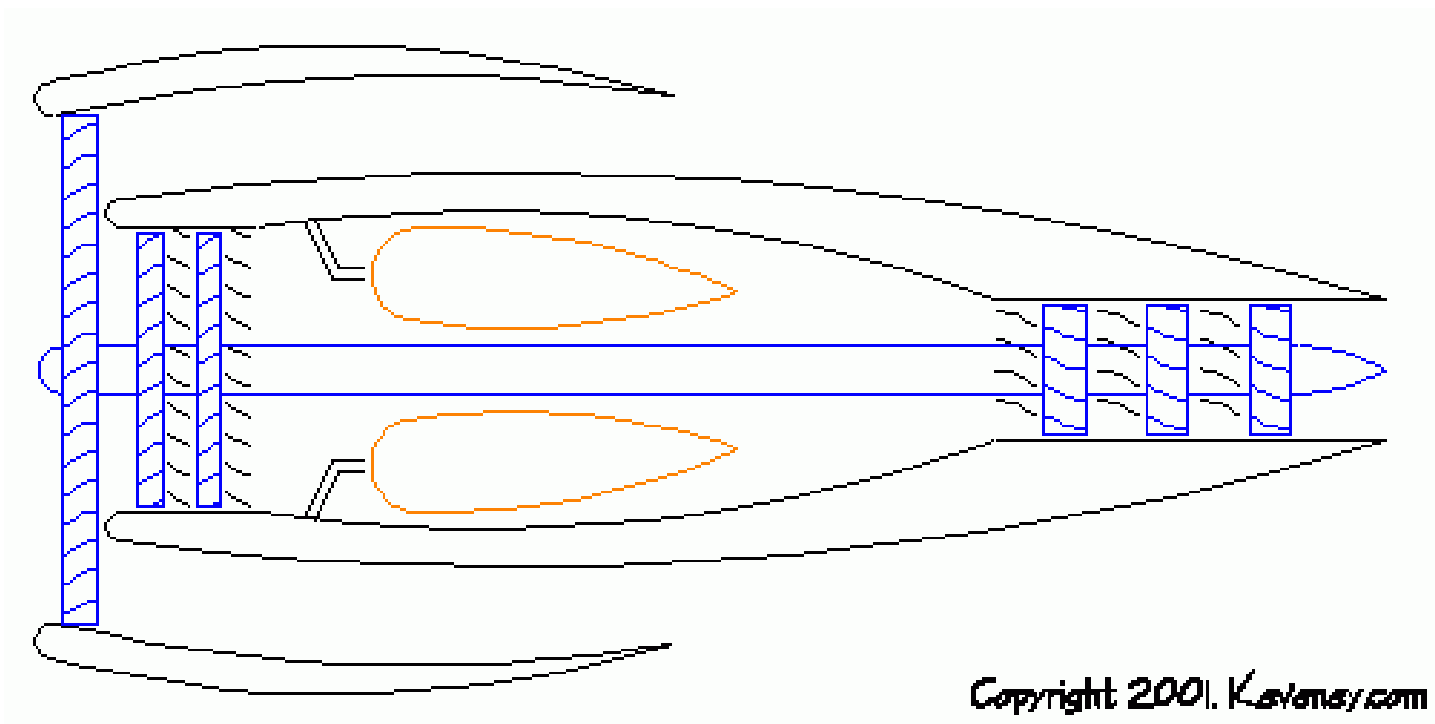

Mlazni motor bez turbine (raketni motor)

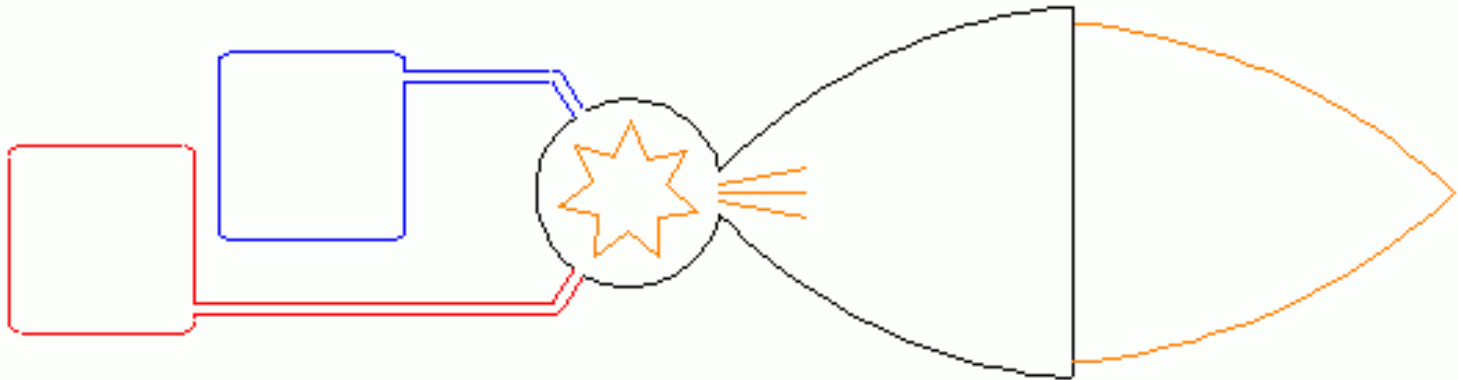

Copyright 2001, Keveney.com

Turbina i kompresor mlaznog motora

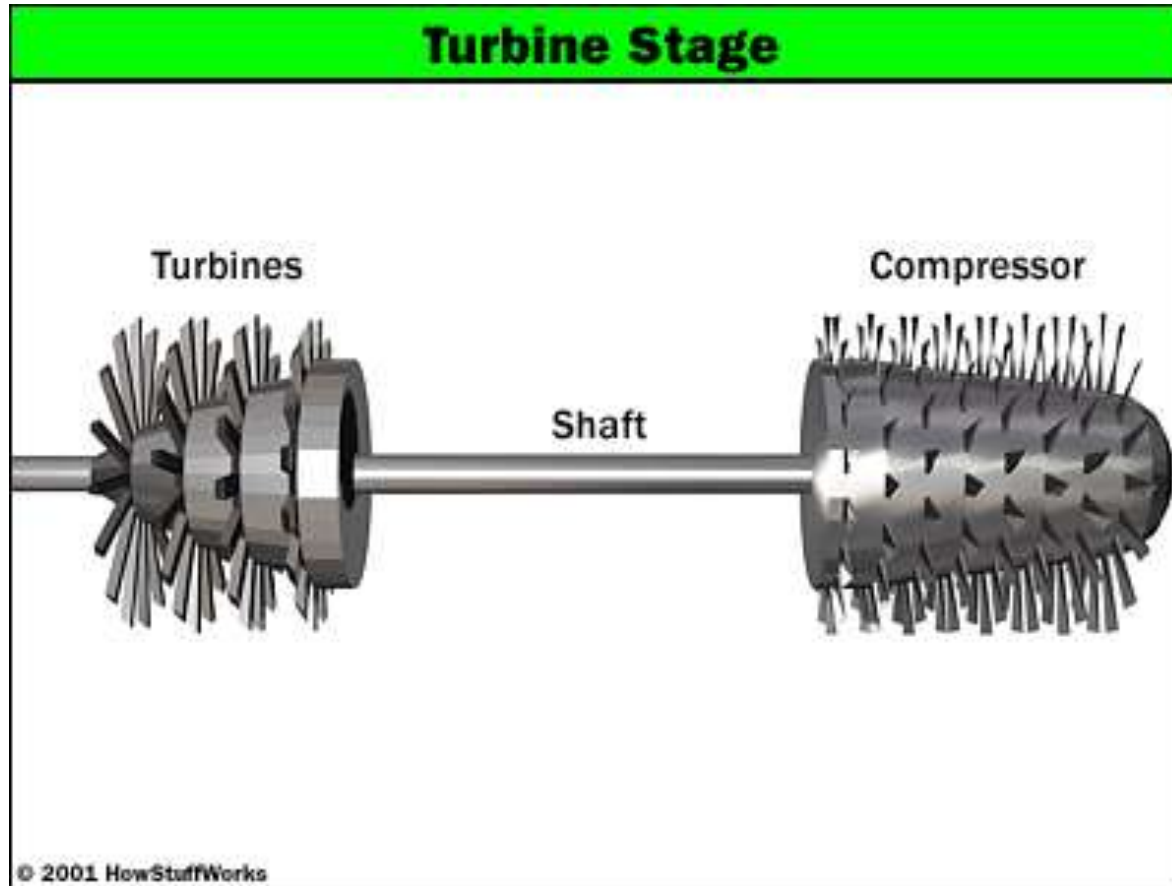

Brodski 2-taktni diesel motori 60-100 o/min

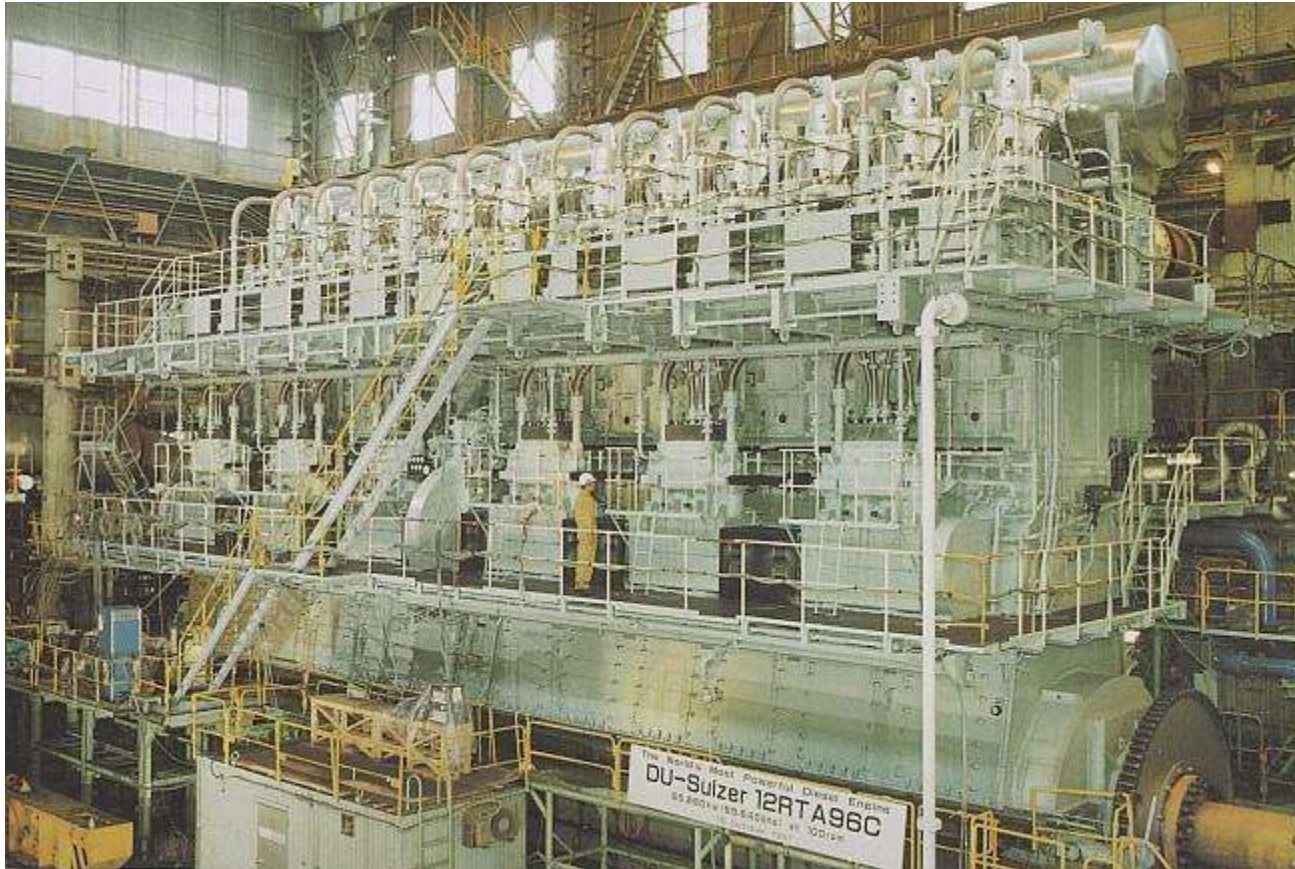

Cilindarski blok

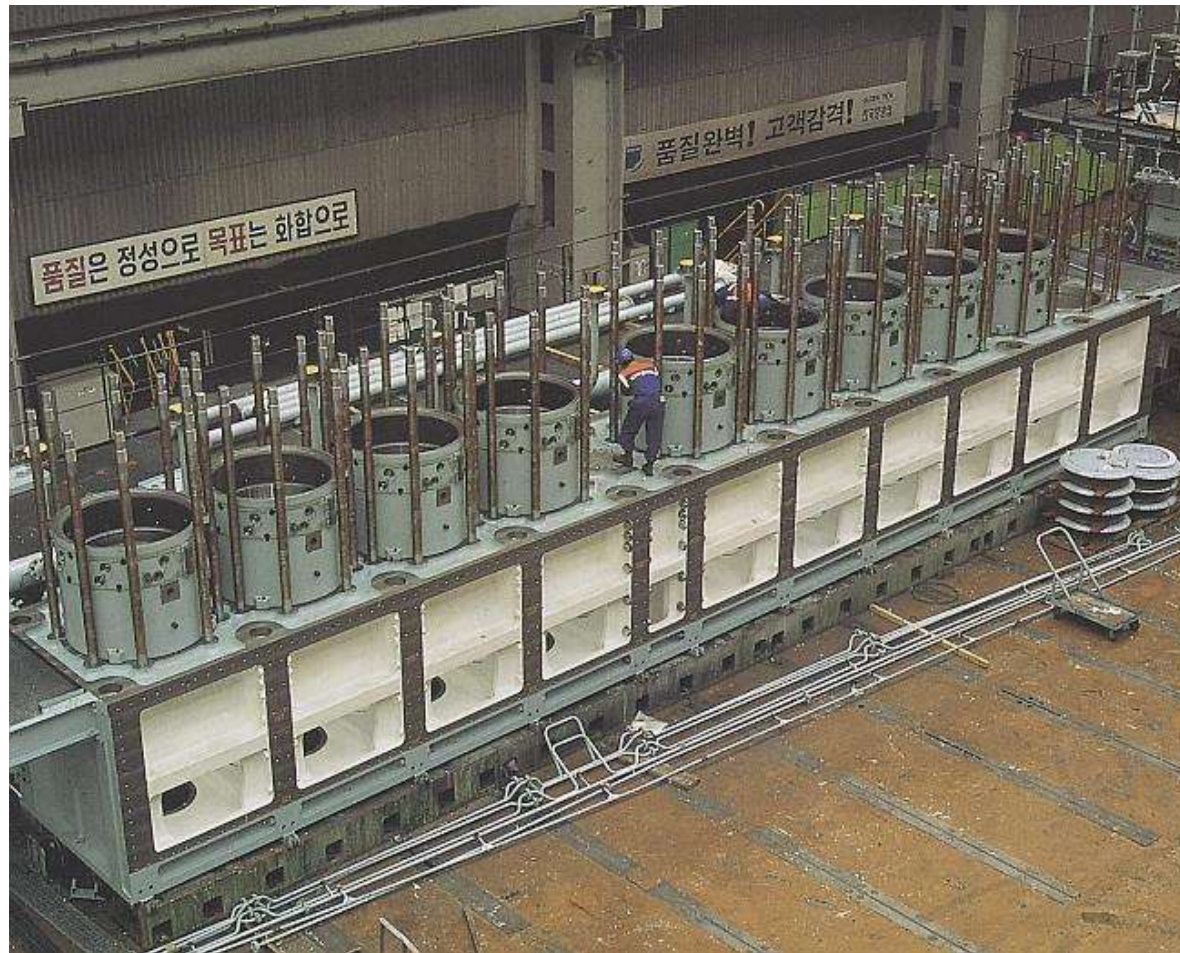

Klip i klipnjača



Koljenasto vratilo

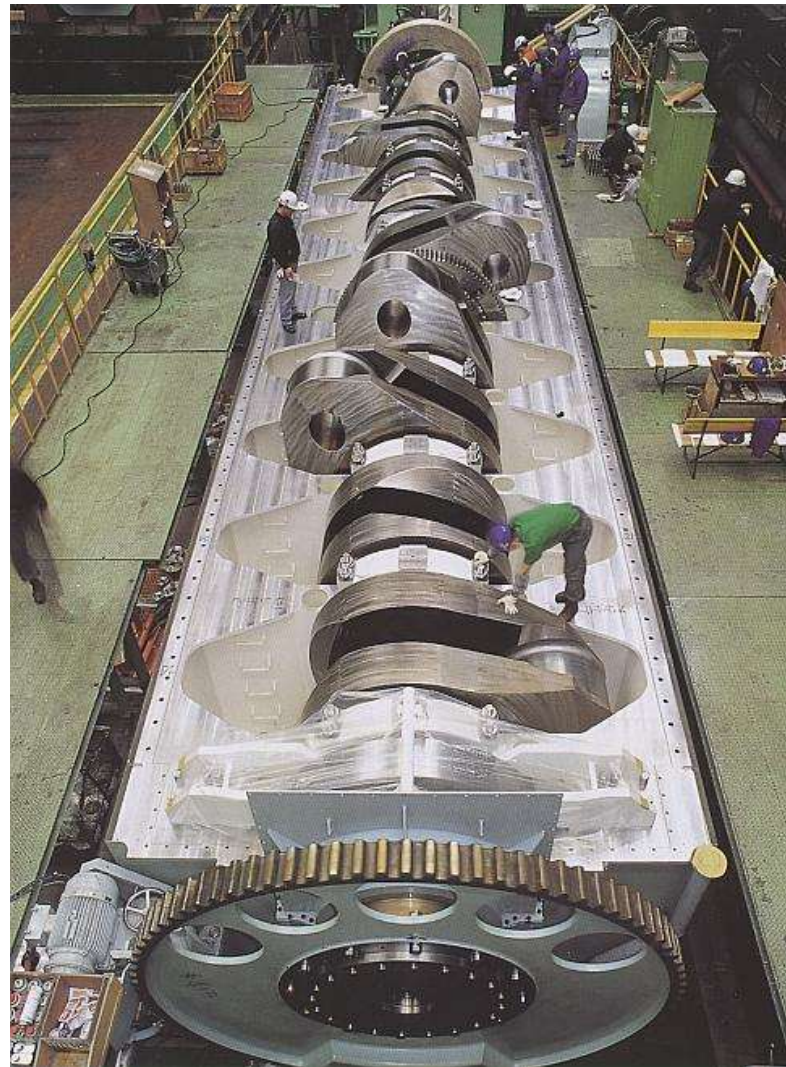

Ležajevi koljenastog vratila

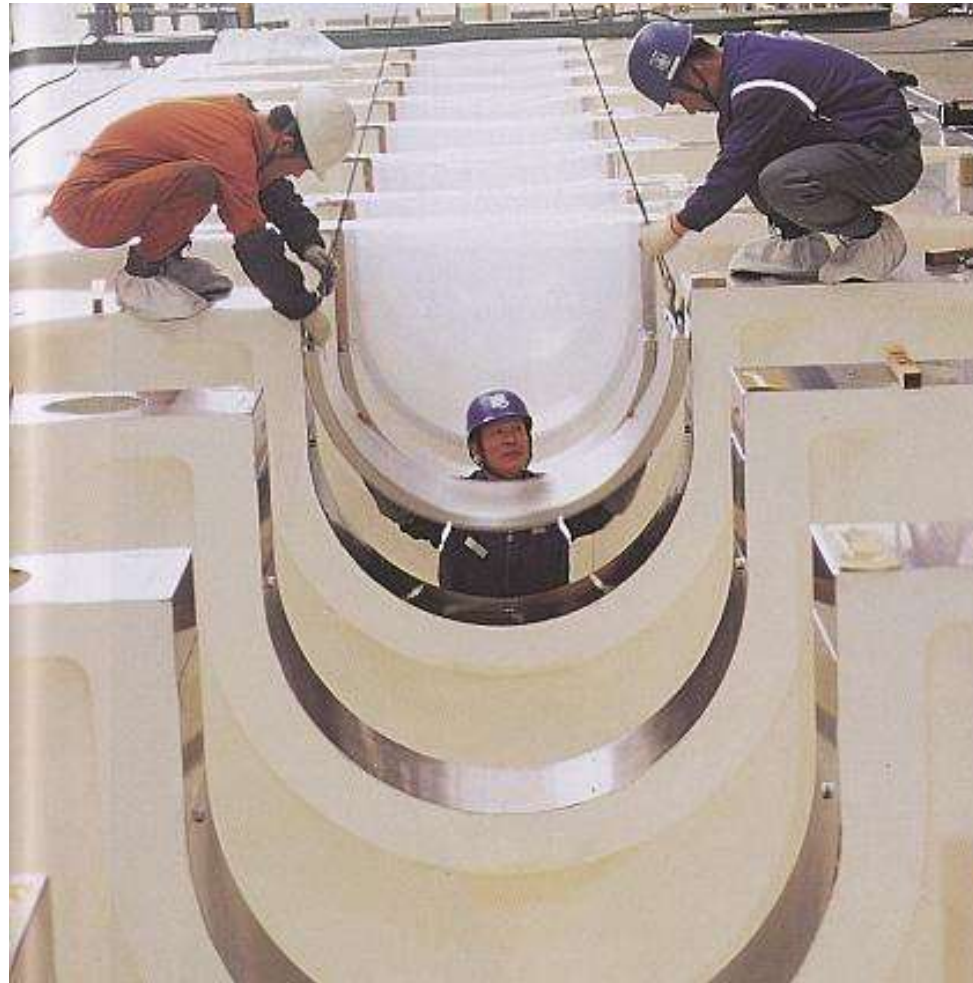

Presjek 2-t diesel brodskog motora 108.920 KS kod 102 o/min. 14 cilindara

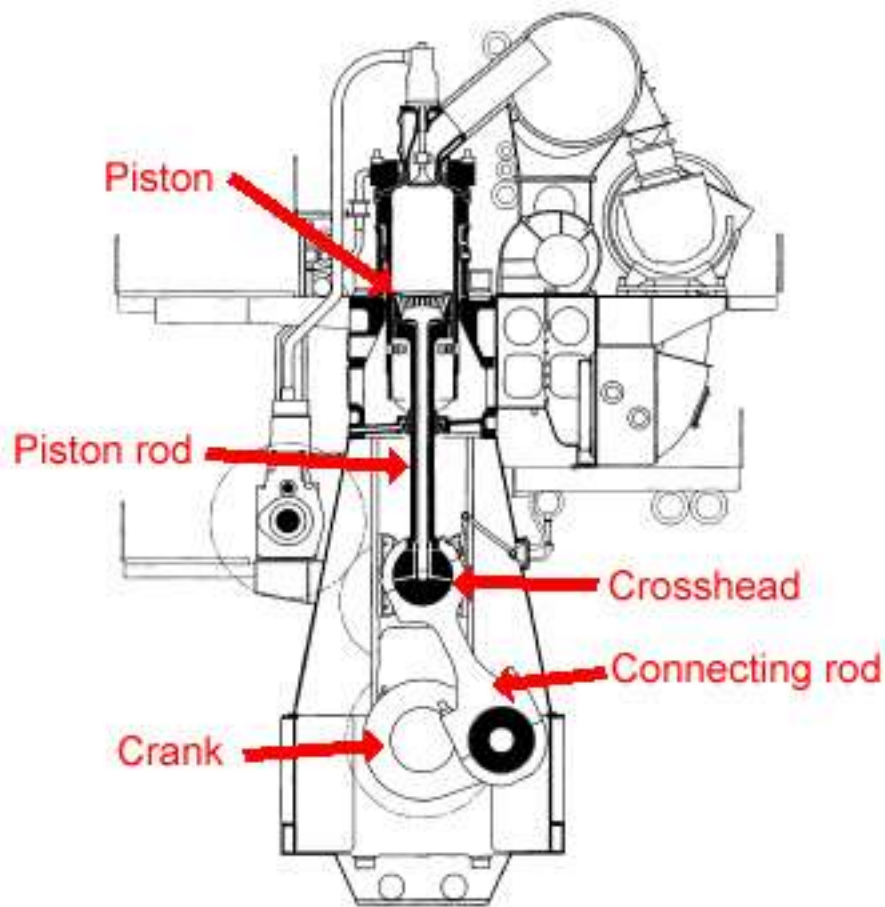

Konstrukcija motora SUI

Nepokretni dijelovi

- cilindarski blok
- cilindarska glava
- korito motora (karter)

Pokretni dijelovi

- motorni (klipni) mehanizam
- razvodni mehanizam

Pomoćni uređaji

- uređaj za napajanje gorivom
- uređaj za podmazivanje
- uređaj za hlađenje
- uređaj za paljenje
- uređaj za pokretanje
- uređaj za usis i ispuh

Nepokretni dijelovi motora

- Cilindarski blok



John Deere-blok, glava, kompletan motor



- Suhe cilindarske košuljice



CILINDARSKE KOŠULJICE

- Suhe košuljice
(lijevo)
- Mokre košuljice
(desno)

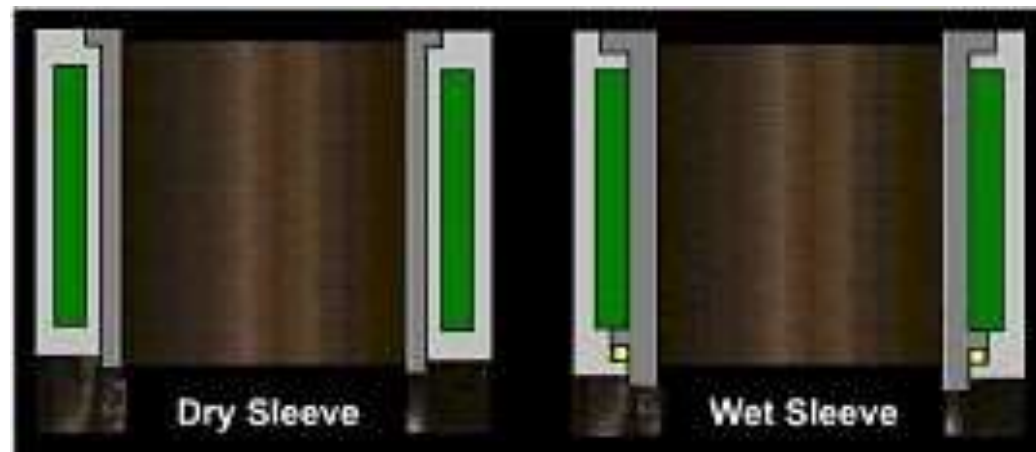

- Cilindarska košuljica



- Cilindarska glava





Cilindarska glava - presjek



Glava, blok i korito motora

- Korito motora (karter)

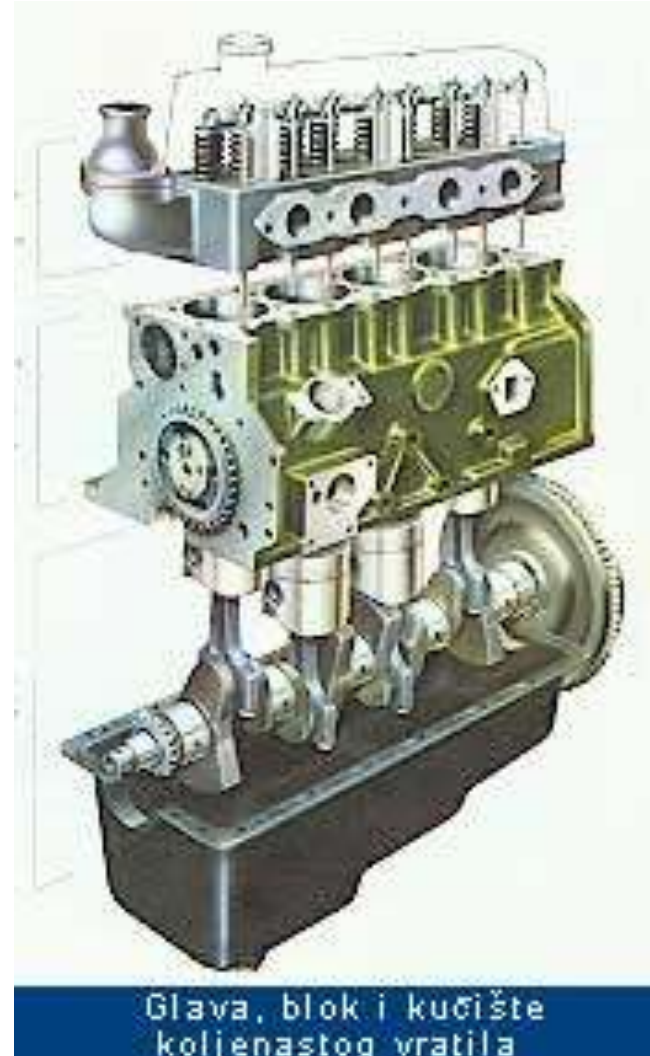

Glava, blok i kućište
koljenastog vratila

Pokretni dijelovi motora

- Klipni (motorni) mehanizam



Klip i klipnjača



John Deere – klip i klipni prstenovi



Koljenasto vratilo



Zamašnjak i spojka



Razvodni mehanizam

- Ventilski razvodni mehanizam



Ventili, sjedišta ventila i vođice



Bregasto vratilo



DOHC-dva bregasta vratila u glavi – pogon lancem



OHC – bregasto vratilo u glavi – pogon zupčastim remenom



Bregasto vratilo u bloku-podizači- klackalice – pogon zupčanicima

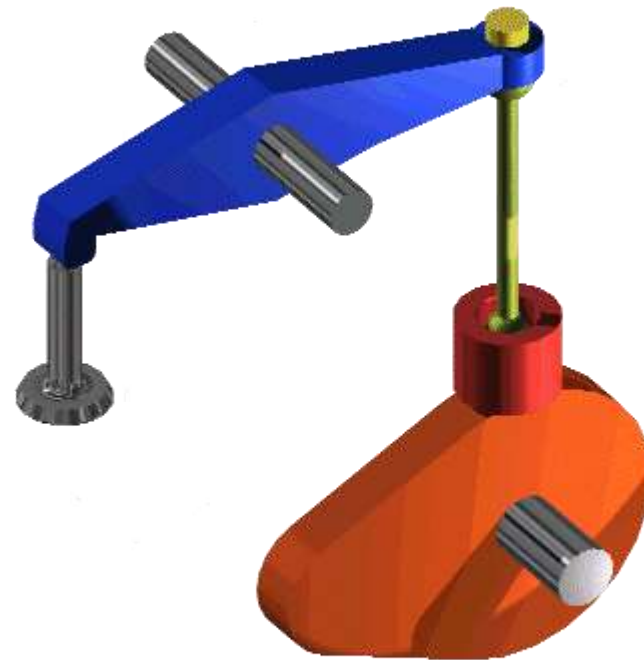
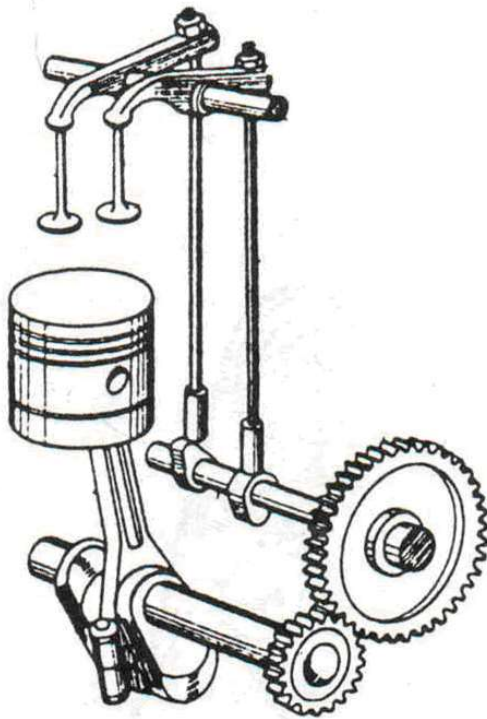

Razvodni mehanizam sa stojećim ventilima

- Ventili su u bloku, kao i bregasto vratilo
- Bregasto vratilo preko podizača podiže ventile



Motor sa stojećim ventilima

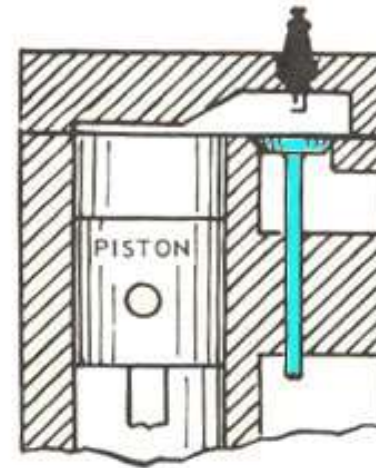
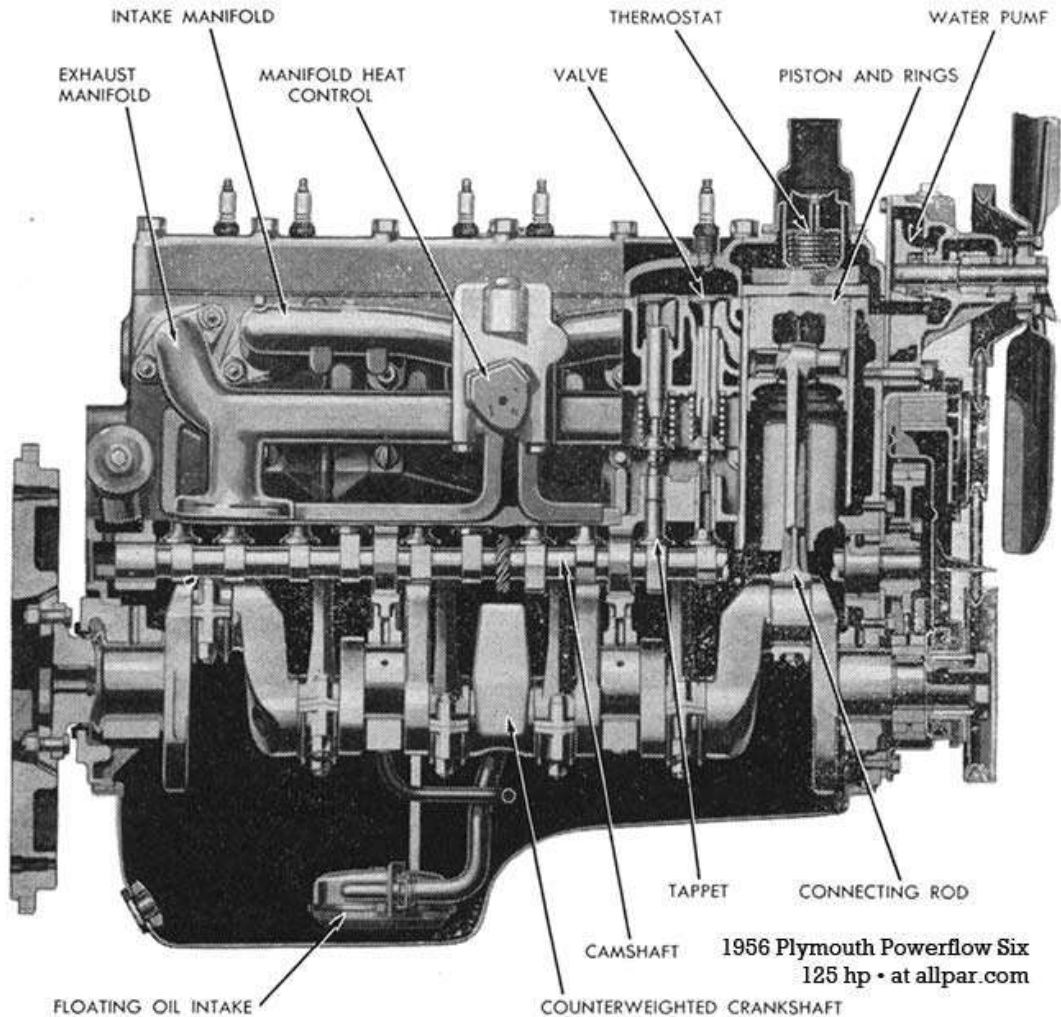

Valves

Cylinder

Form an inverted letter L

Pomoćni uređaji motora

- Uređaj za napajanje gorivom otto motora
 - Spremnik goriva (rezervoar)
 - Niskotlačna crpka za gorivo
 - Rasplinjač (karburator) ili sustav ubrizgavanja

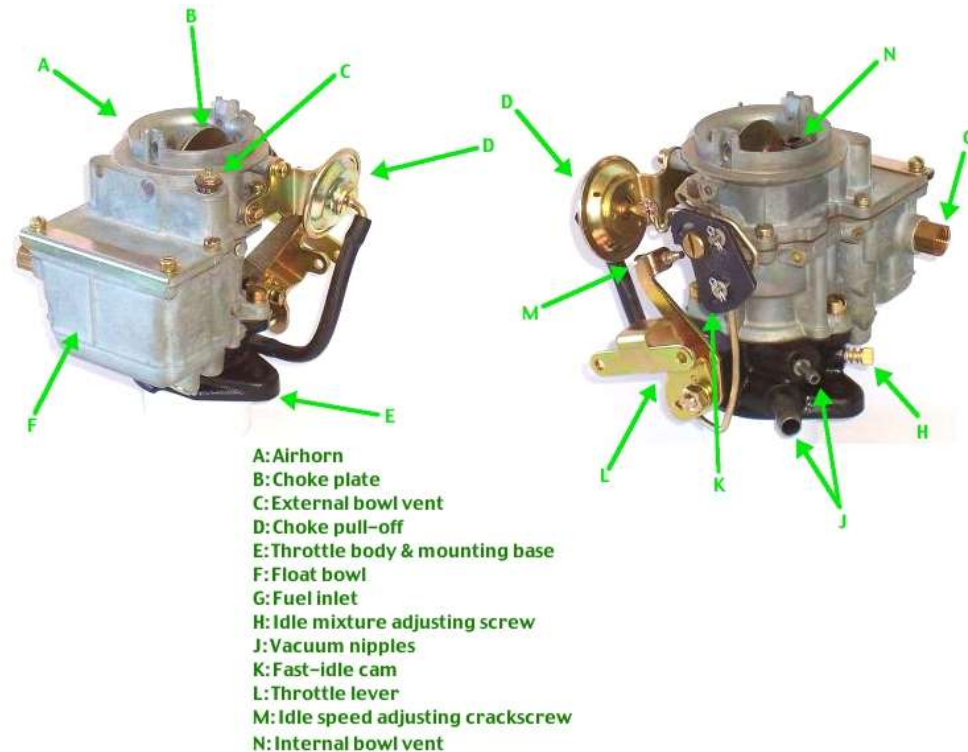

Elementarni rasplinjač

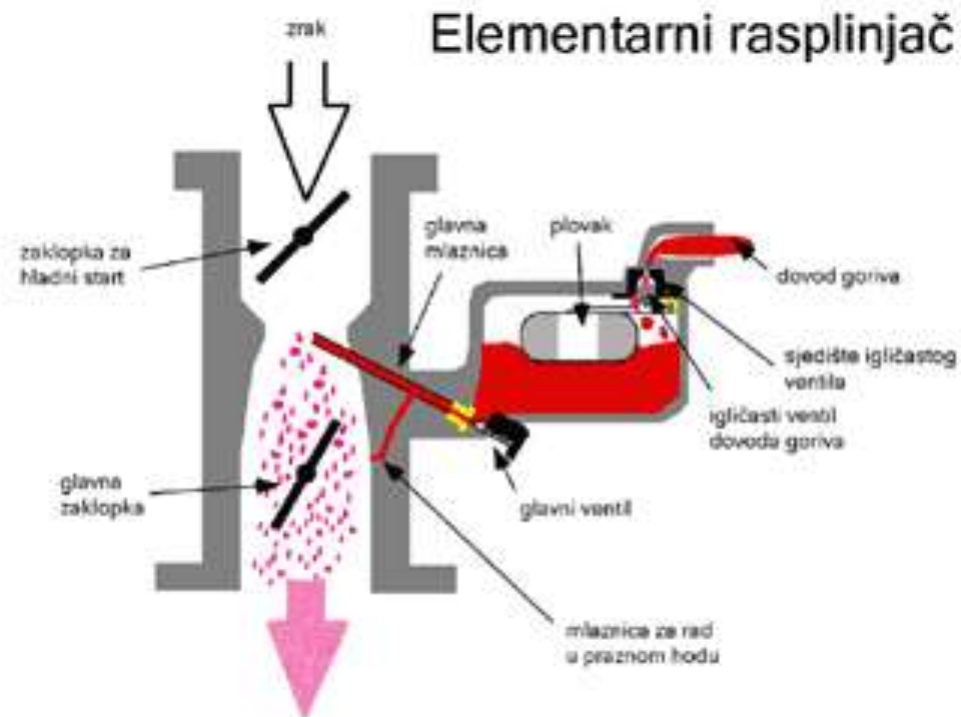

Brizgaljka goriva otto motora

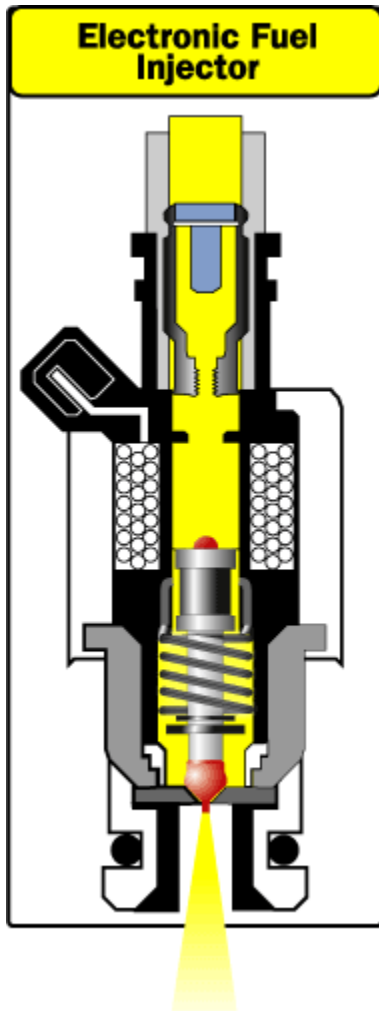

Uređaj za napajanje gorivom diesel motora

- Spremnik goriva (rezervoar)
- Taložnik (taložna čašica)
- Niskotlačna crpka za gorivo
- Prečistači goriva (grubi i fini)
- Visokotlačna crpka za gorivo
- Brizgaljke

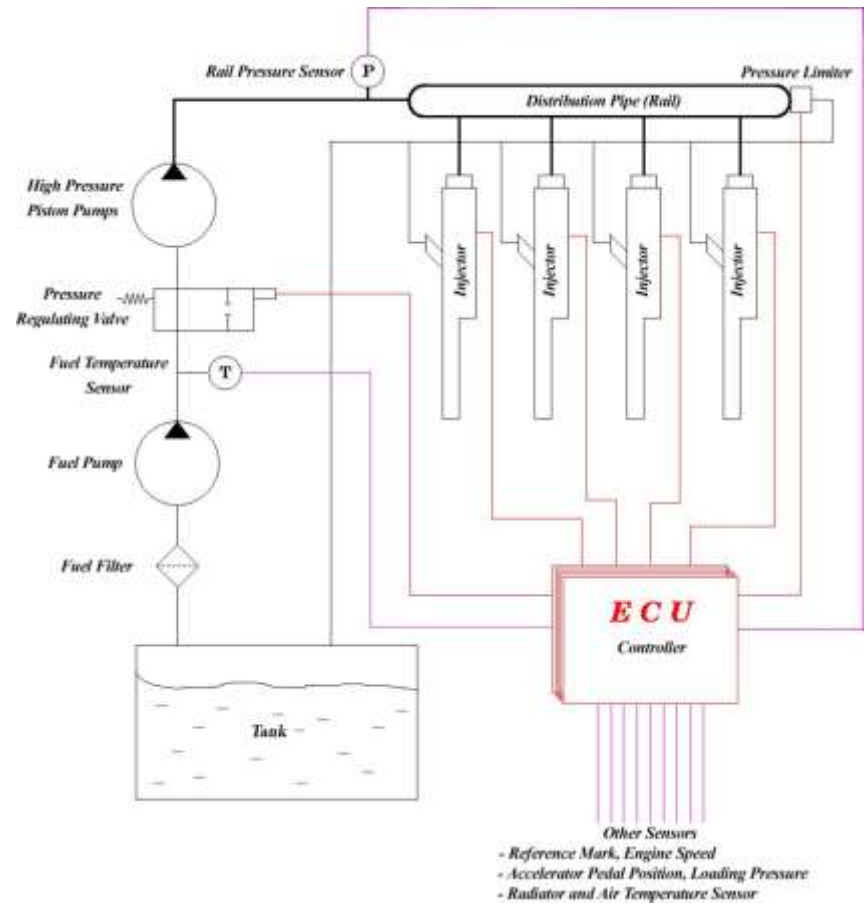

Common rail sustav ubrizgavanja goriva

Common Rail Diesel Fuel Systems

Components overview (example: Bosch EDC 16)

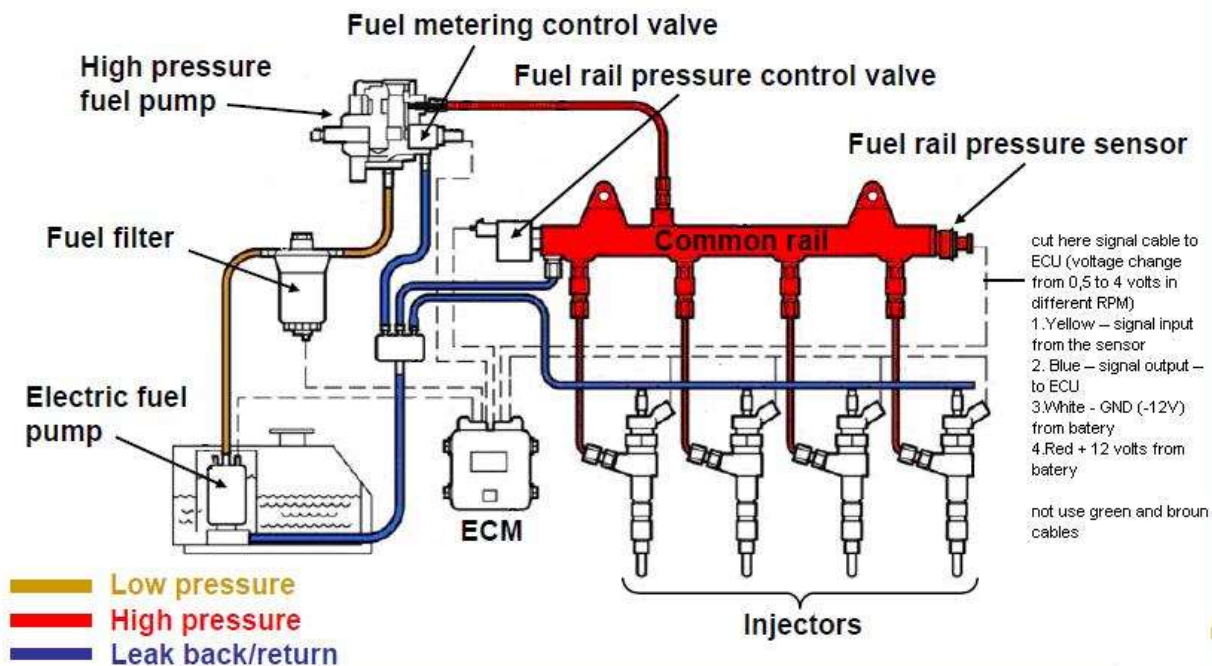

Uređaj s rednom (linijskom) visokotlačnom crpkom

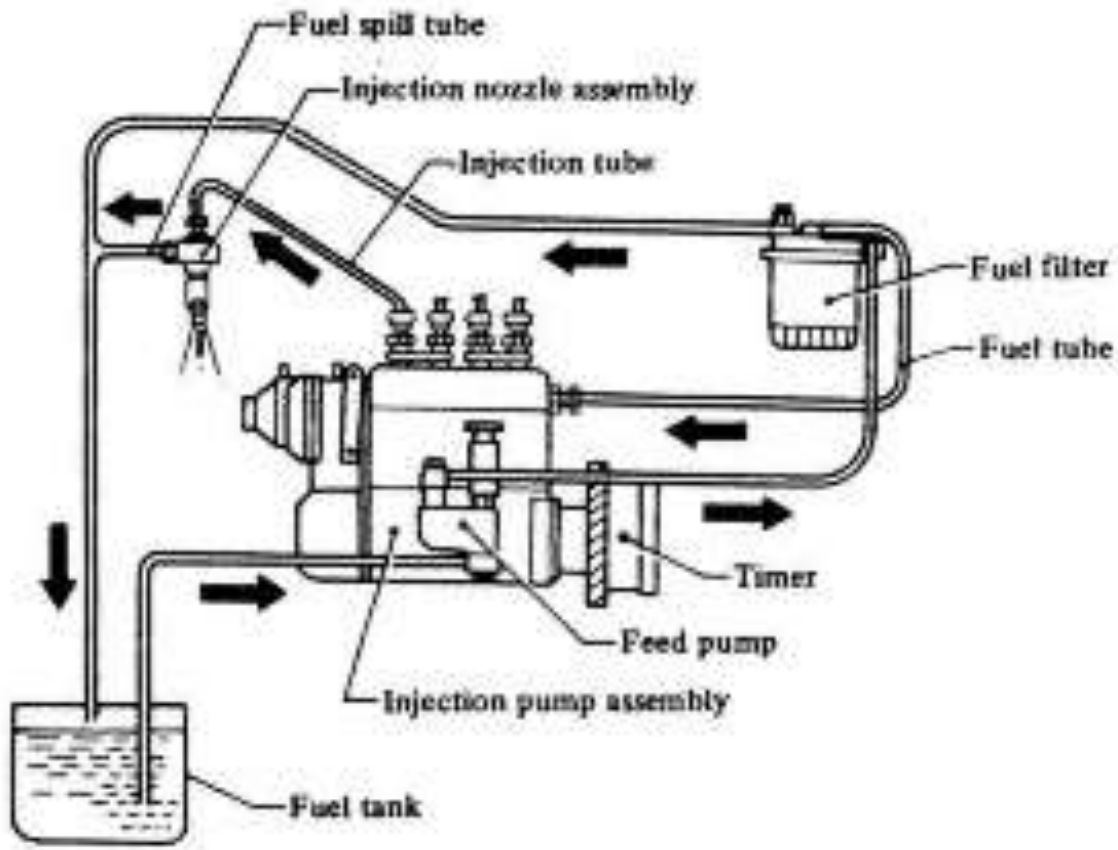

Niskotlačna crpka za gorivo

- Klipna ili membranska

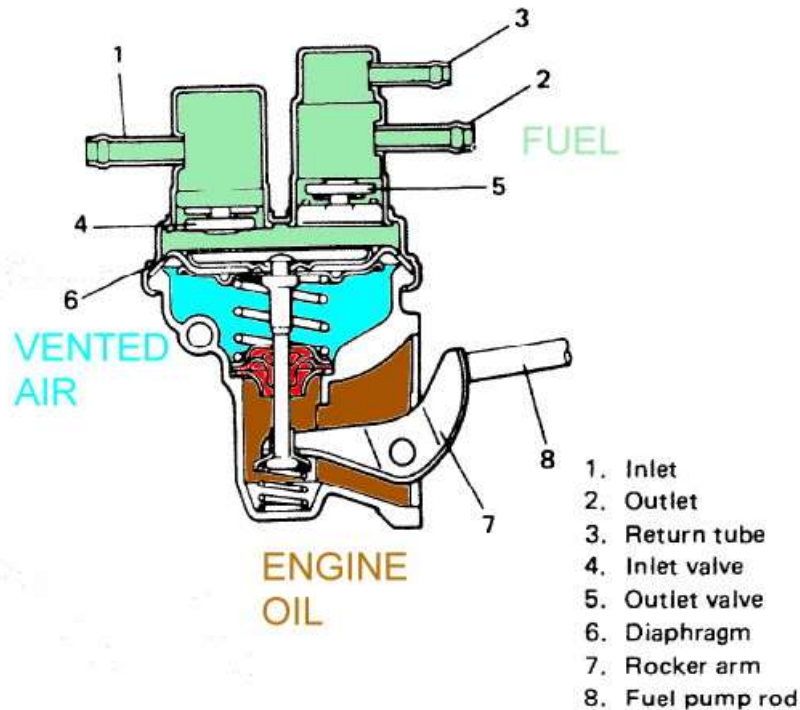
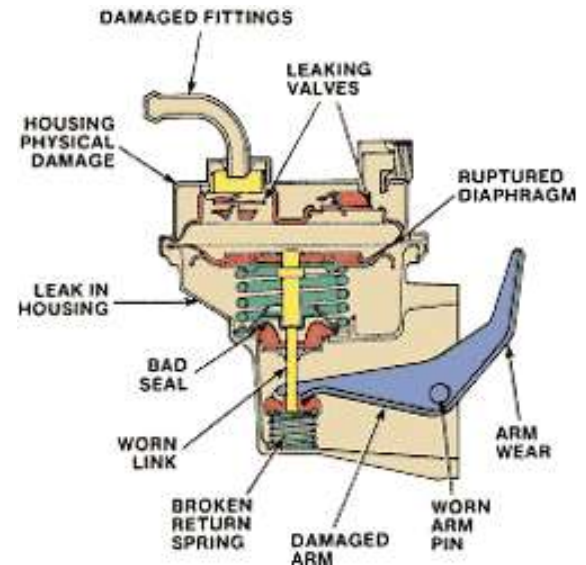

Fig. 4-2-7



Redna visokotlačna crpka za gorivo s pneumatskim regulatorom



Regulacija broja okretaja motora zakretanjem klipova u elementima crpke

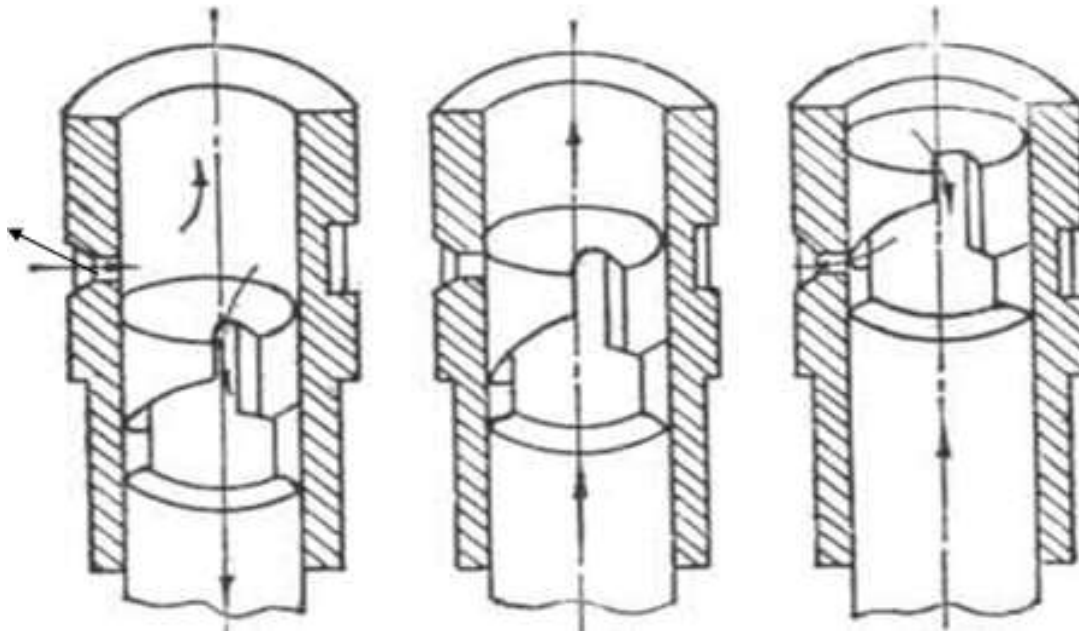

Centrifugalni regulator redne visokotlačne crpke za gorivo

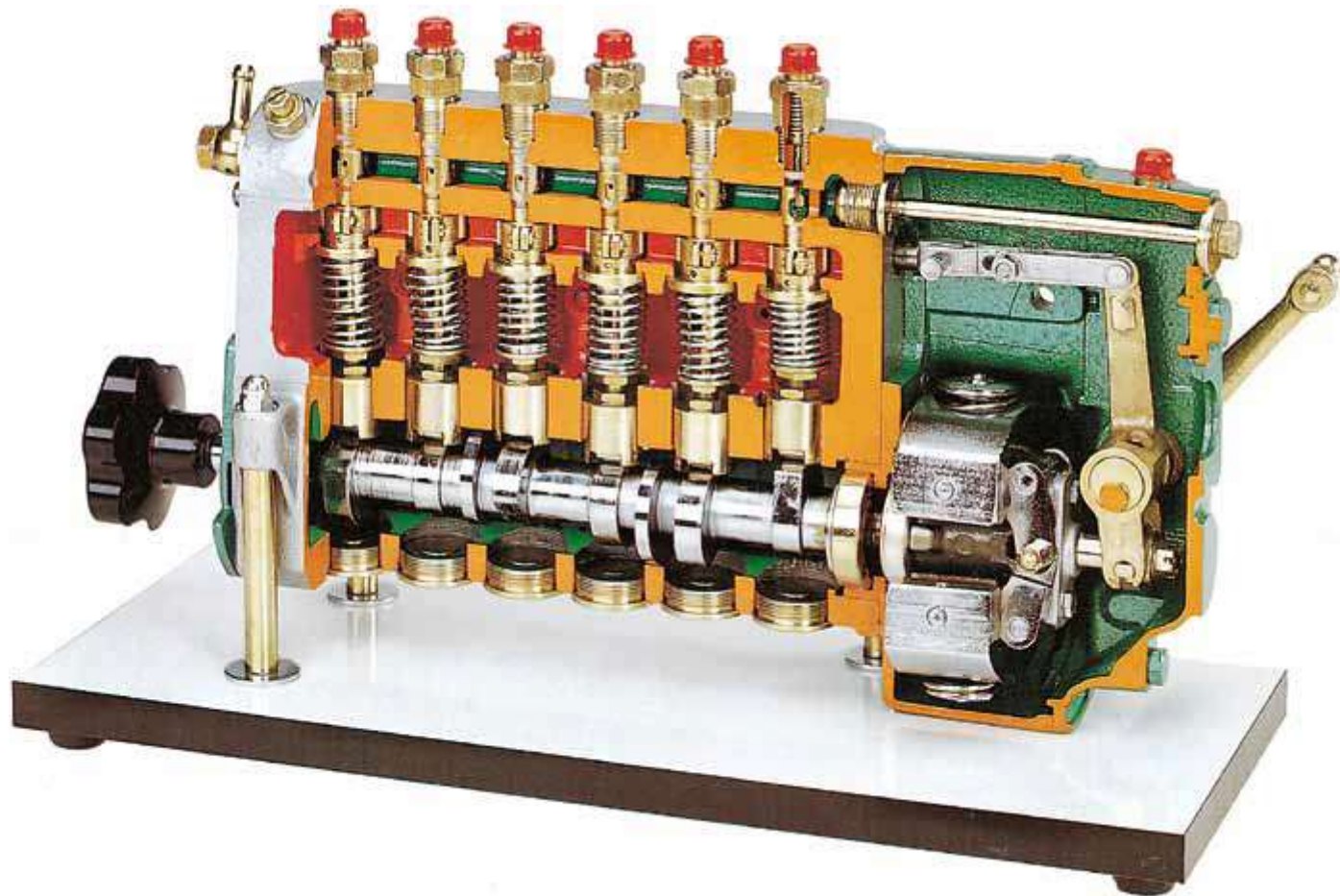

Rotacijska visokotlačna crpka za gorivo

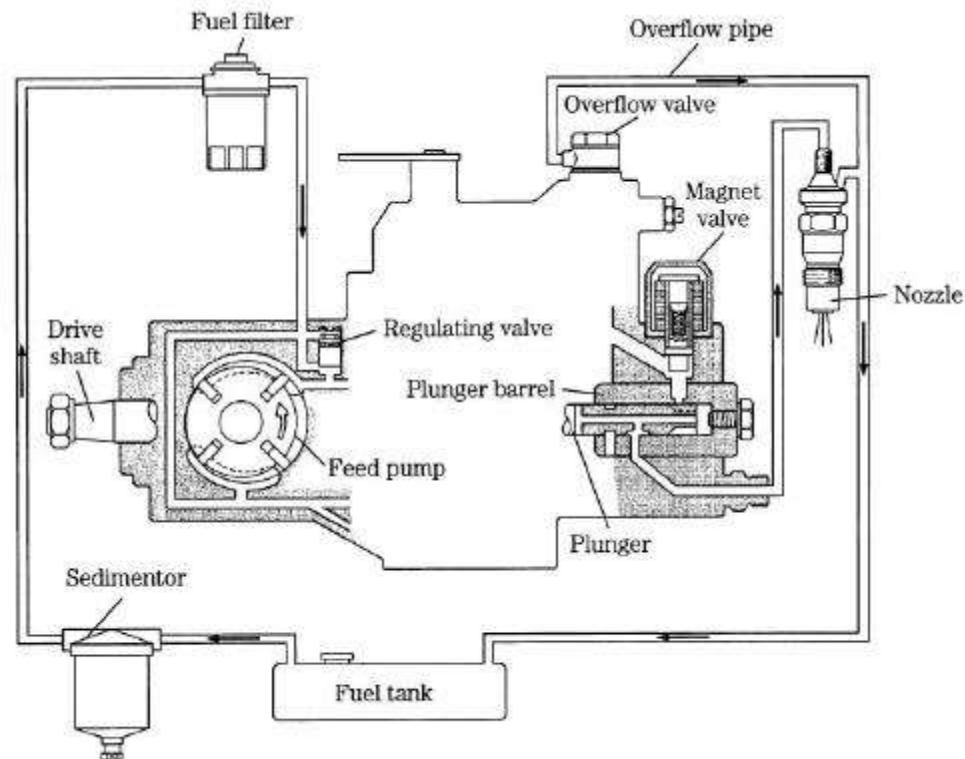

5-9 Typical small-engine distributor-type system. *Yanmar Diesel*

Rotacijska VT crpka za gorivo

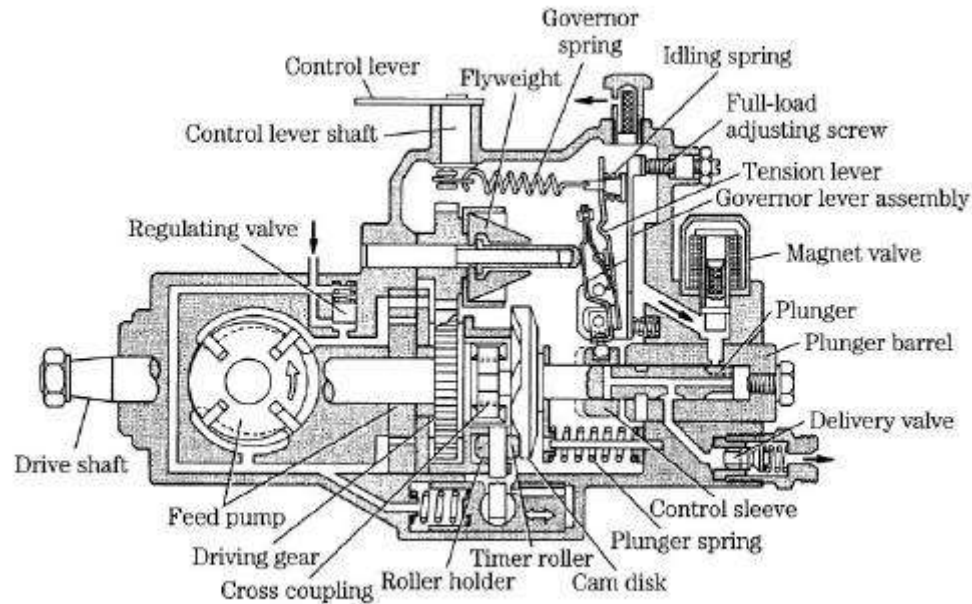

5-10 Bosch VE Series injection pump.

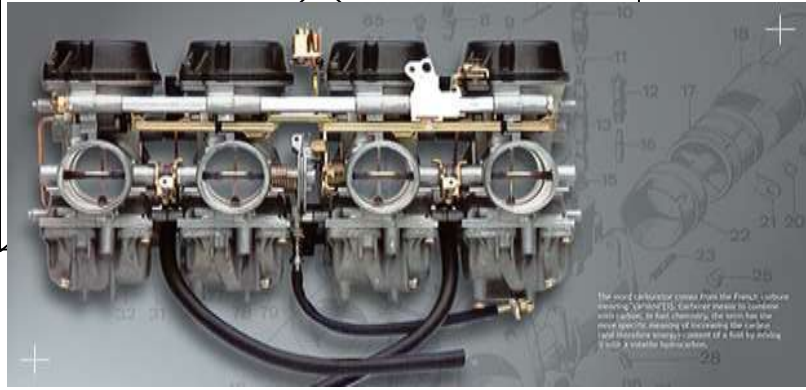
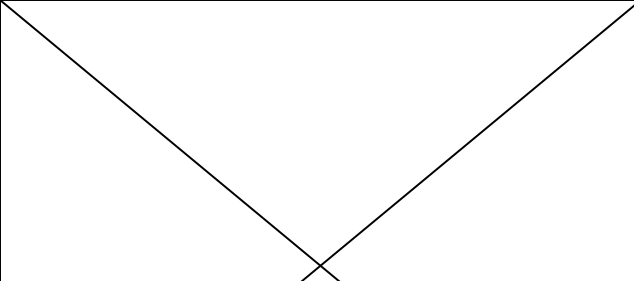

The word carburetor comes from the French carbure meaning "enriched". Carburetors mix air with fuel, so fuel chemistry, the ratio has the most specific meaning of increasing fuel and air total intake energy content of a fuel by adding it into a mixture hydrocarbon.

Uređaj za hlađenje motora

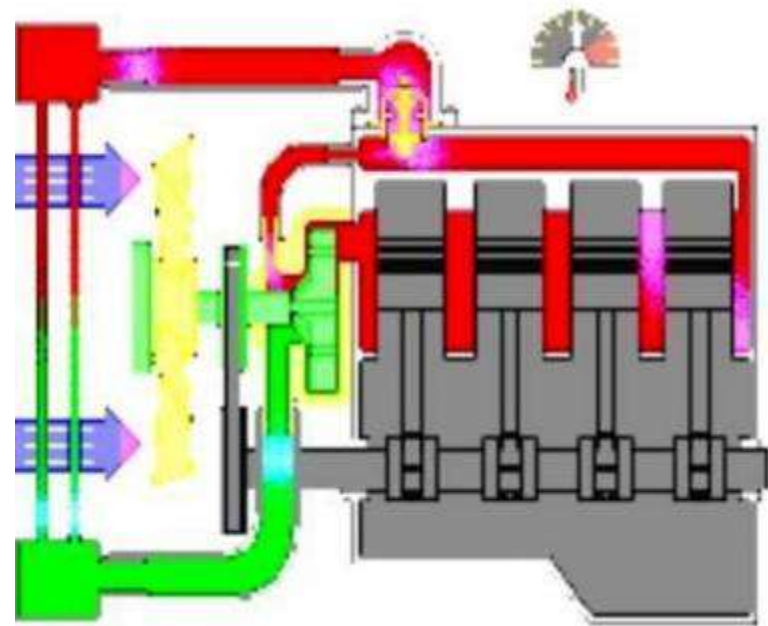
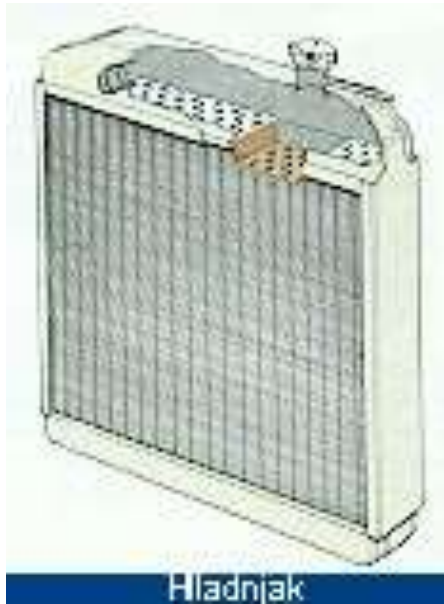

Cirkulacija rashladne tekućine velikim tokom

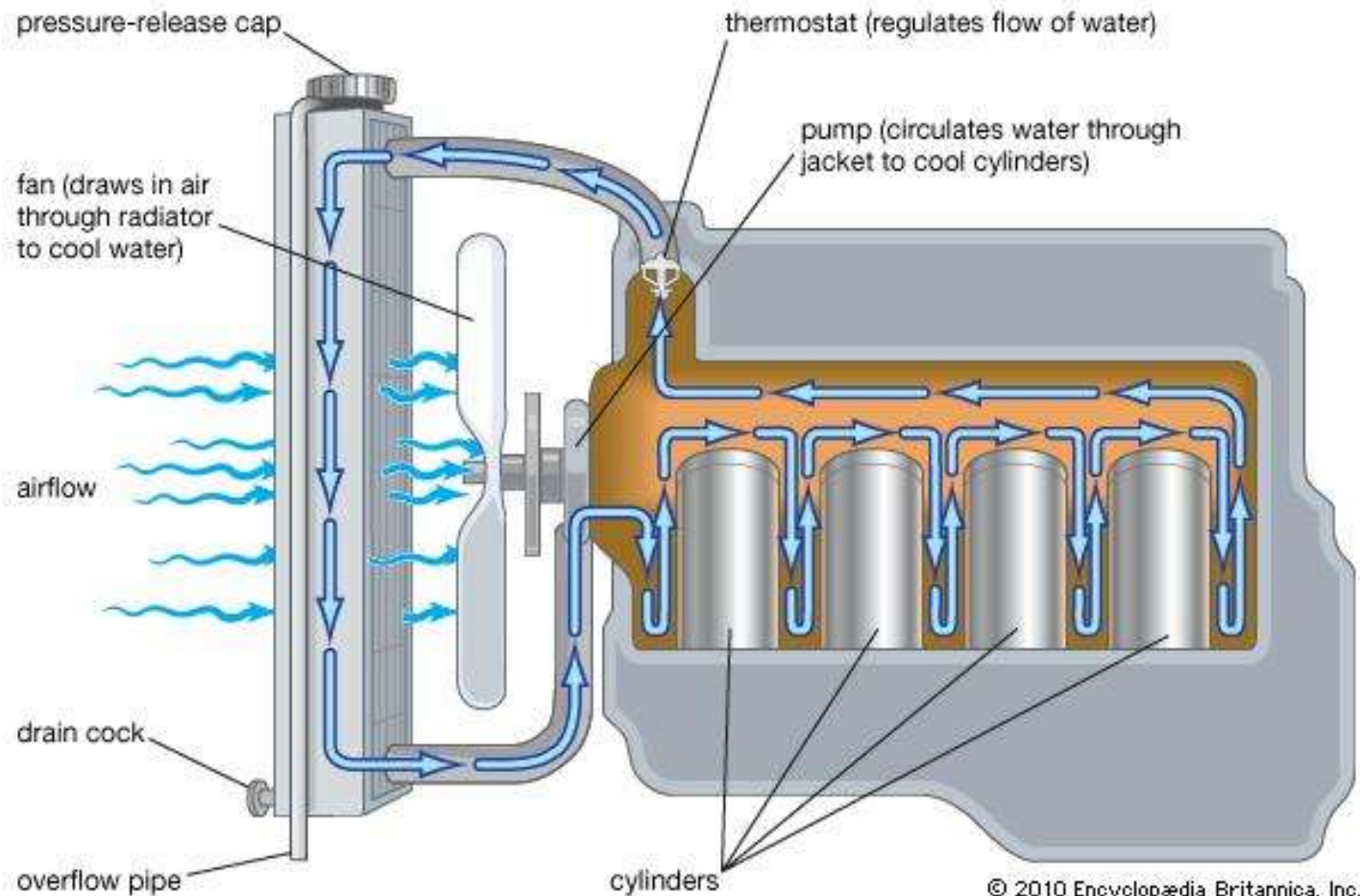

Crpka za rashladnu tekućinu („vodena pumpa”)

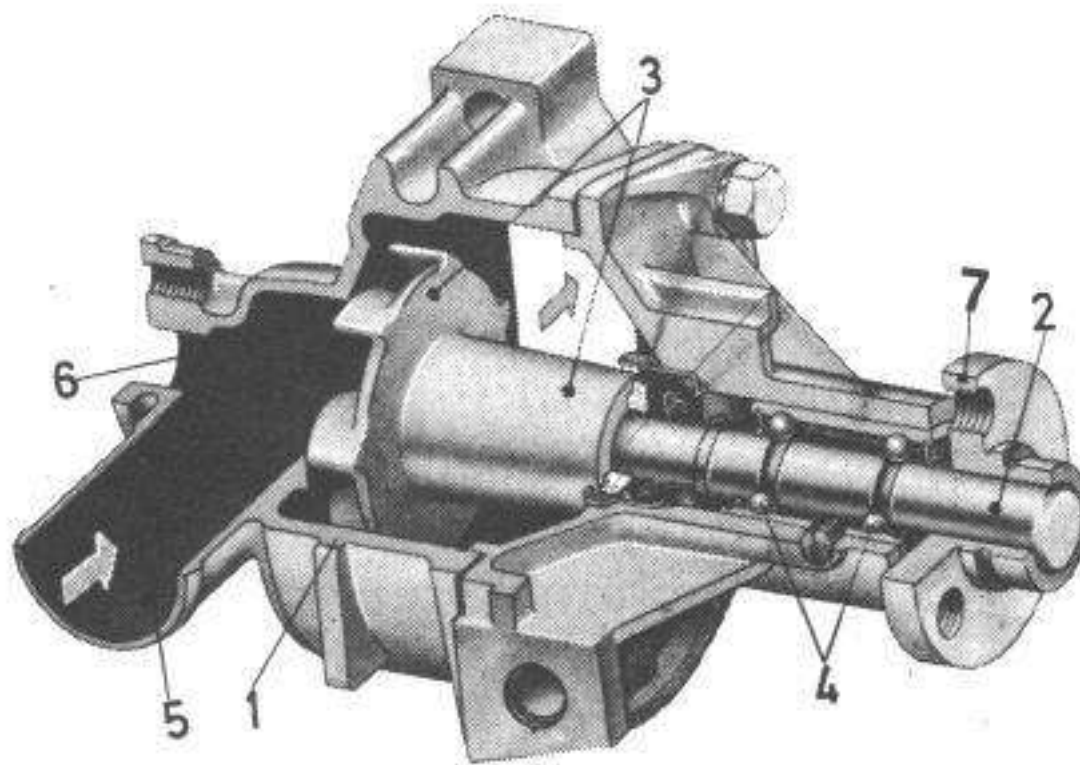

Sredstva protiv smrzavanja - antifriz



Zračno hlađenje motora



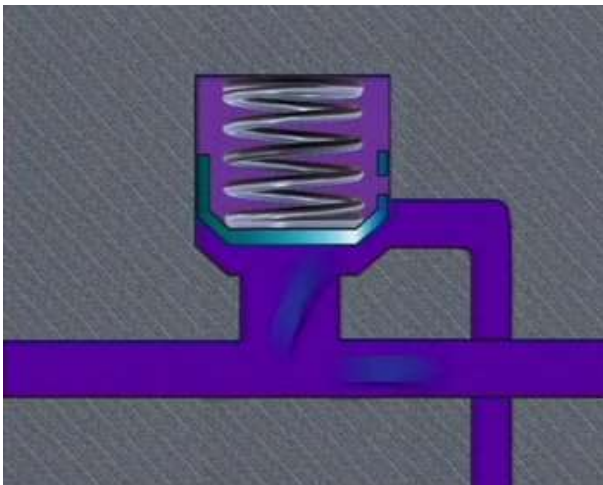
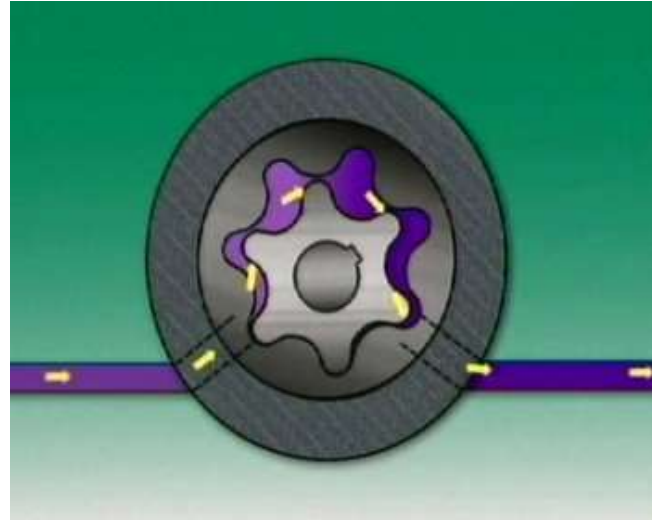

Šupljine za ulje u koljenastom vratilu i mjerna šipka za kontrolu razine ulja u karteru



Uređaj za pokretanje motora elektro-pokretač s el.mag. uključivačem



Shema pokretanja elektropokretača

ELEKTRIČNO POKRETANJE

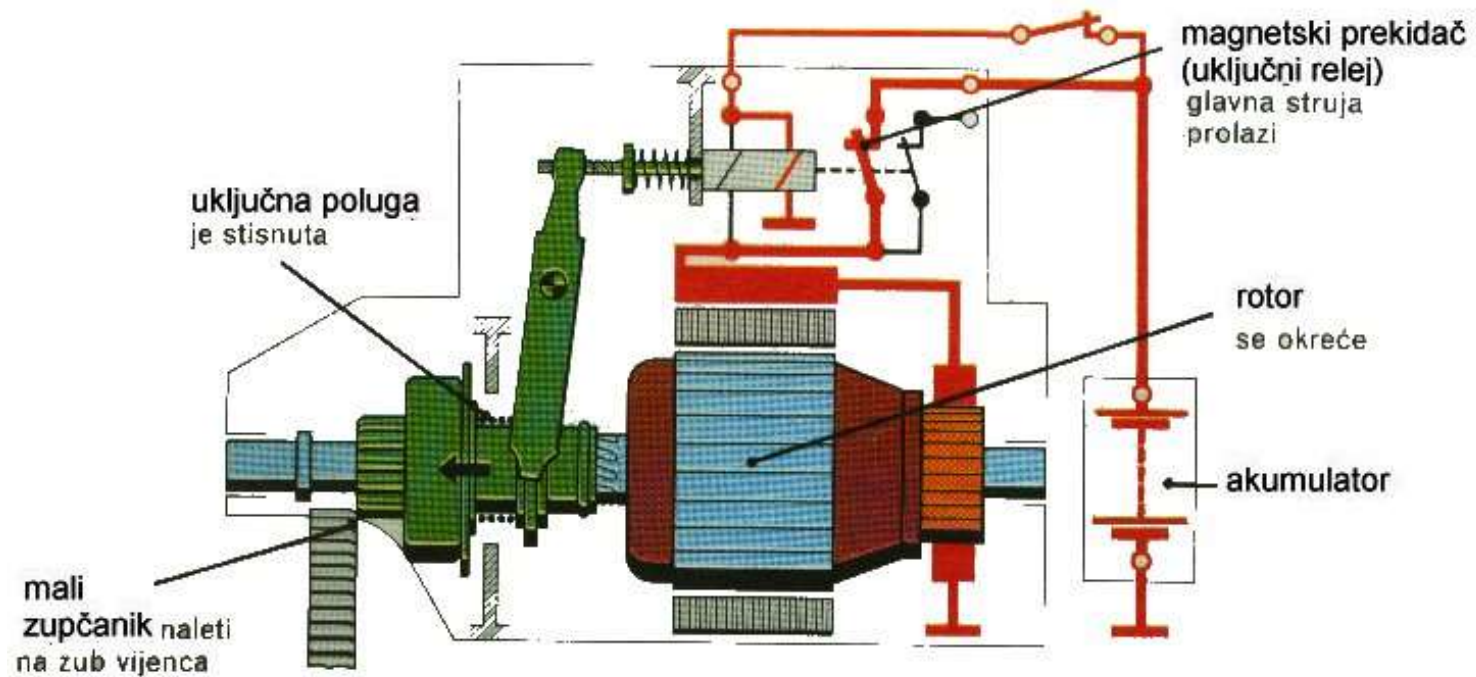

Elektropokretač s pomičnim rotorom

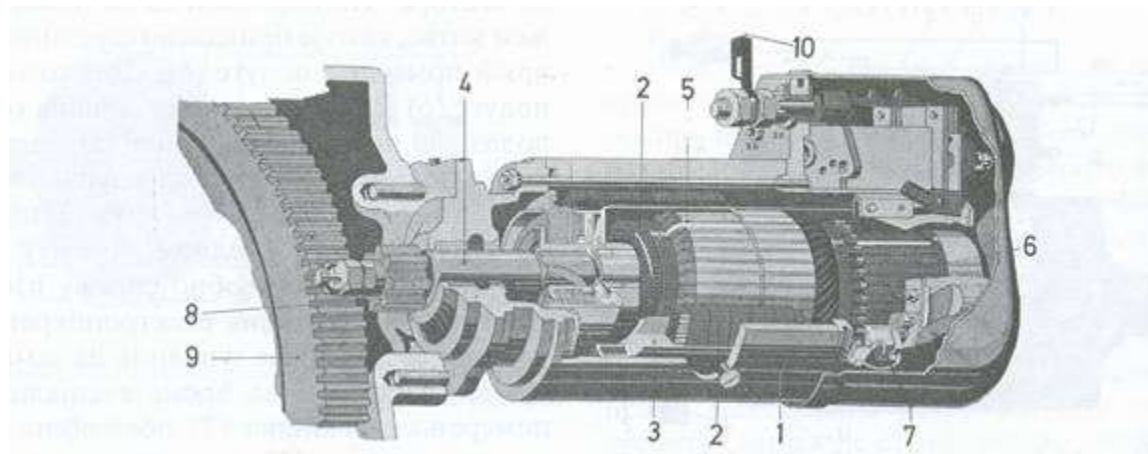

Uređaj za paljenje otto motora baterijsko paljenje

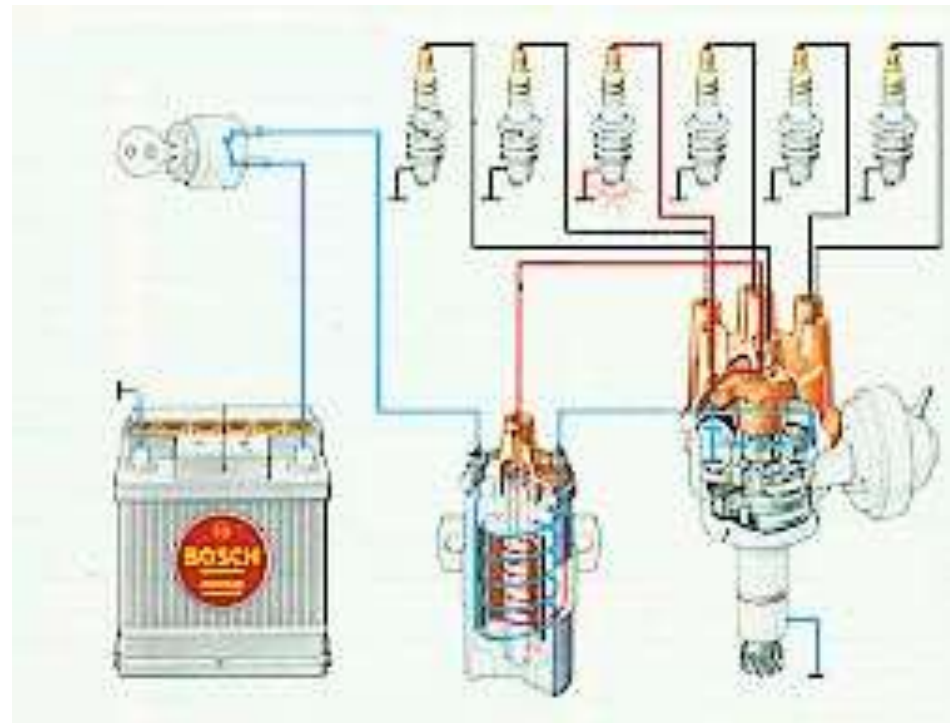

Akumulator, indukcijski svitak, razvodnik paljenja, svjećica

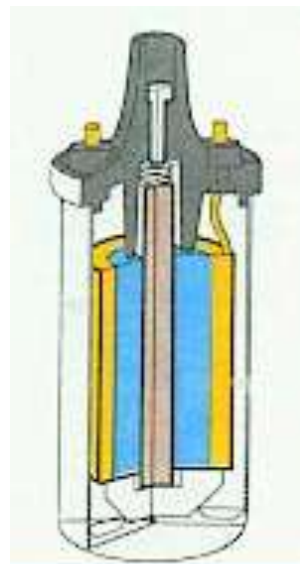
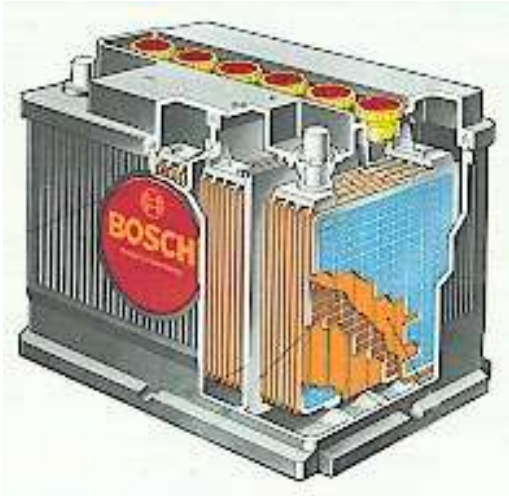

Indukcijski svitak

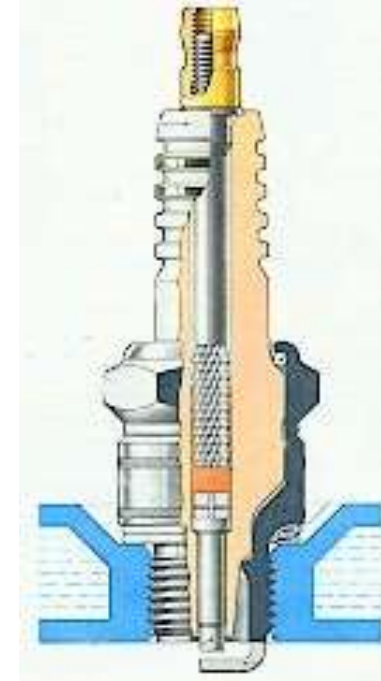

Tehničke karakteristike motora traktora Valtra A 92

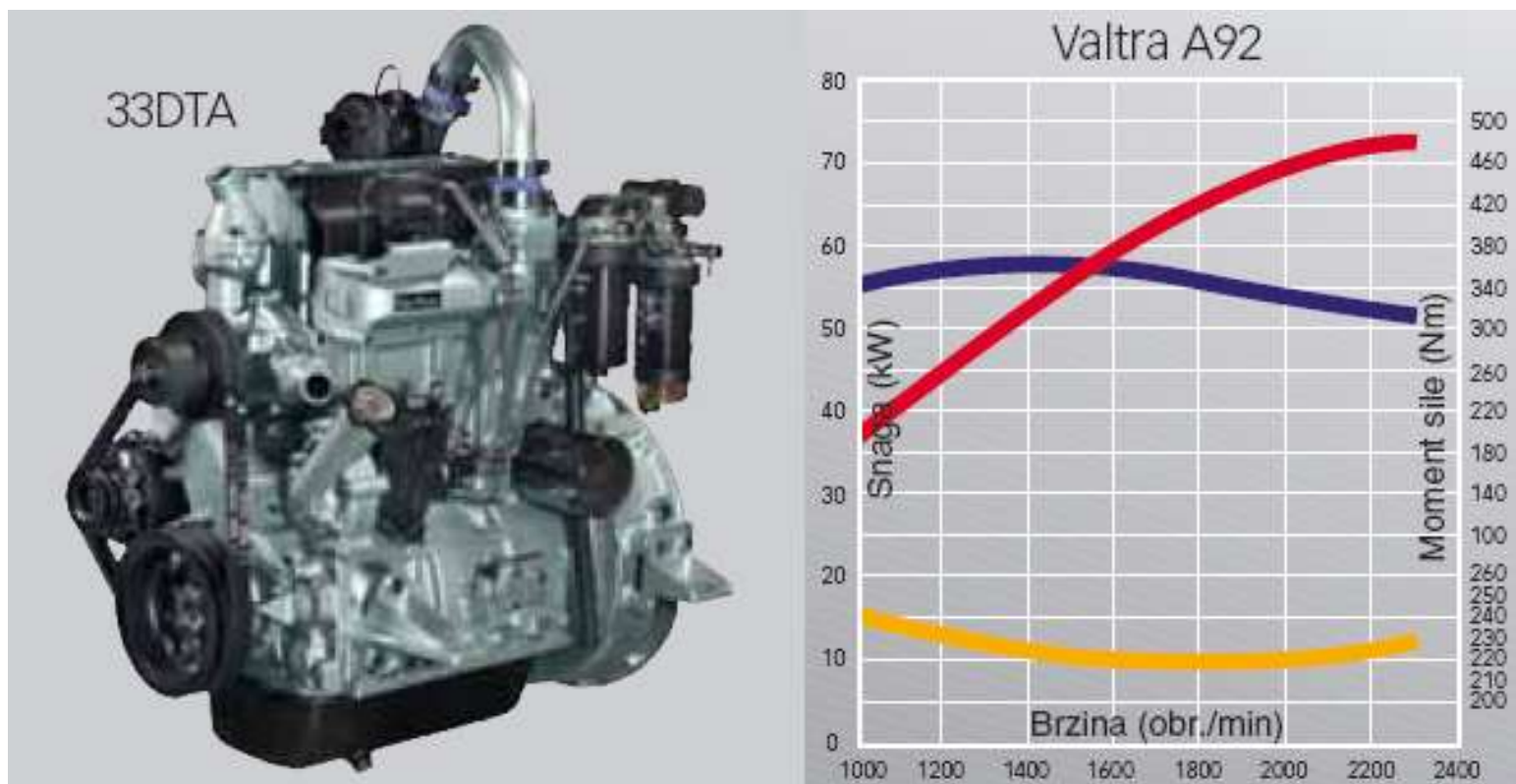

POLJOPRIVREDNI TRAKTOR TRANSMISIJSKI UREĐAJI

- Spojka
- Mjenjač
- Reduktor
- Konusno-tanjurasti prijenosnik
- Diferencijal
- Završni prijenos

SPOJKA (KVAČILO, KUPLUNG)

- Mehanička tarna
- Hidraulička (hidrodinamička, turbo-
kupplung)

Mehanička tarba spojka

1-struka tanjurasta spojka

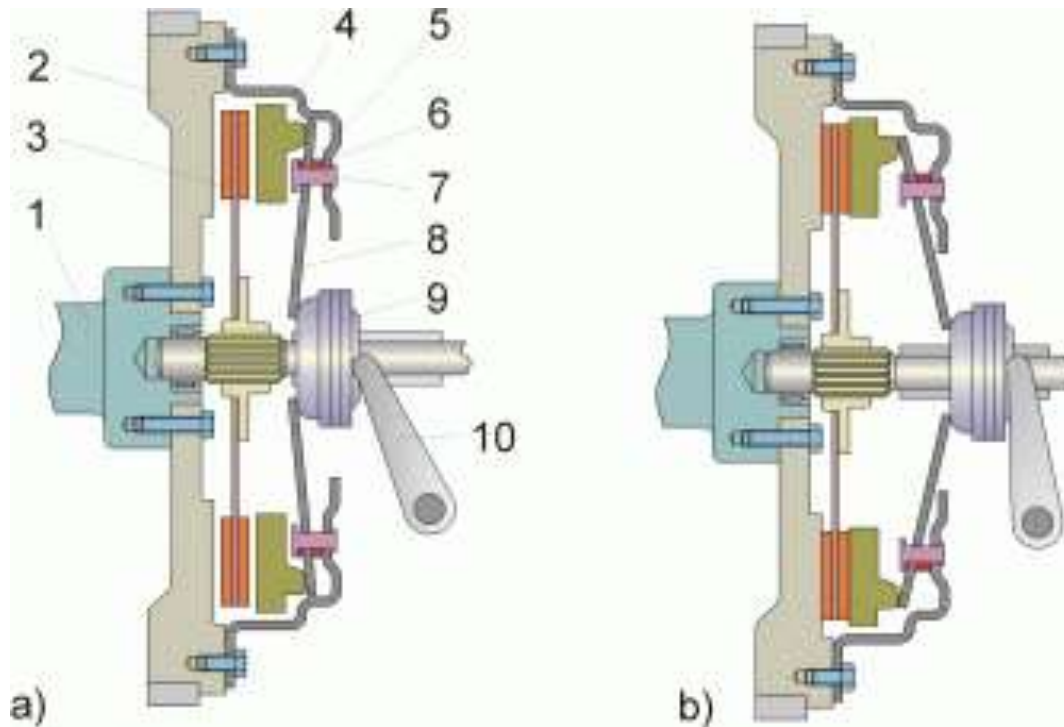

1-struka tanjurasta spojka



Potisni ležaj spojke s hidrauličnim vodom



Dvostruka tanjurasta spojka

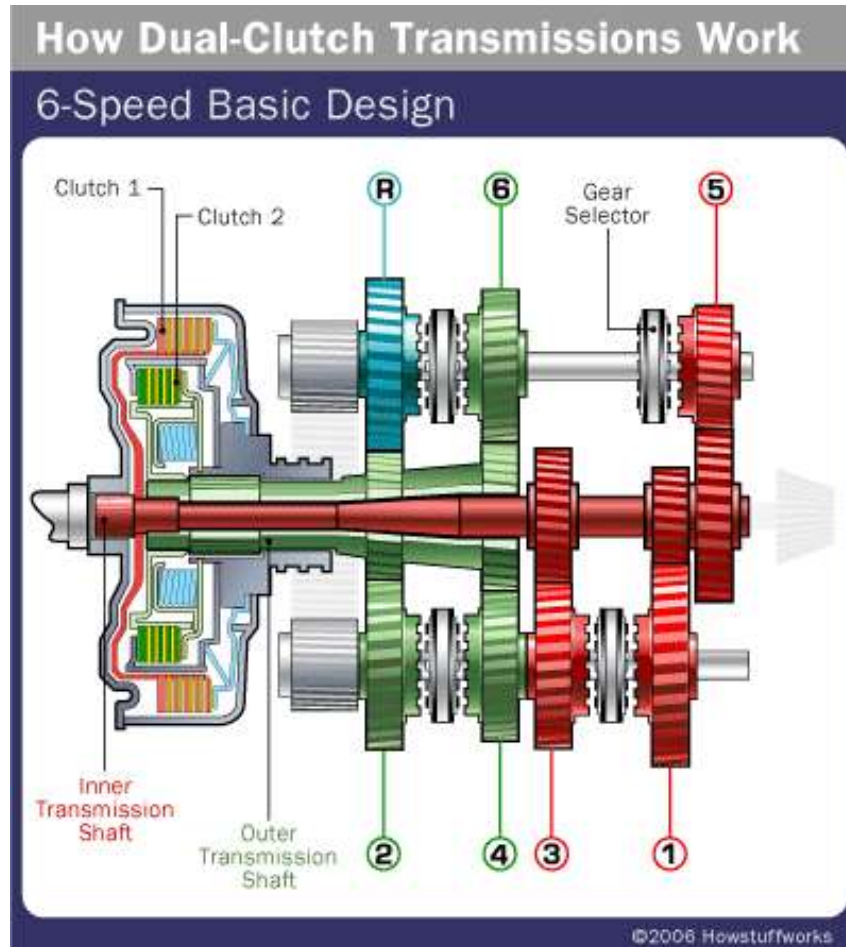

Hidrodinamička spojka

- Sklop turbine i pumpe – cirkulacija ulja s lopatica pumpe čiji rotor okreće koljenasto vratilo na lopatice turbine prenosi okretni moment na spojničko vratilo

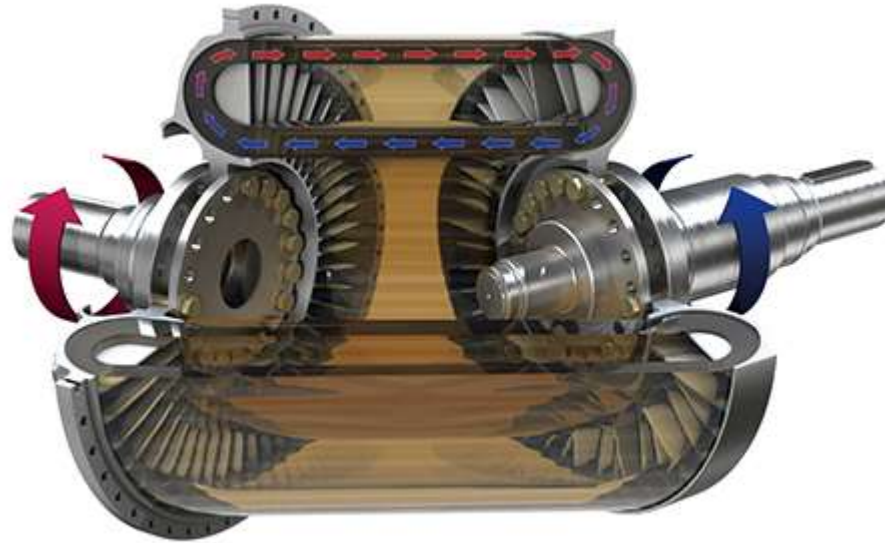

Fendt turbo kuplung



Transmisija traktora Valtra

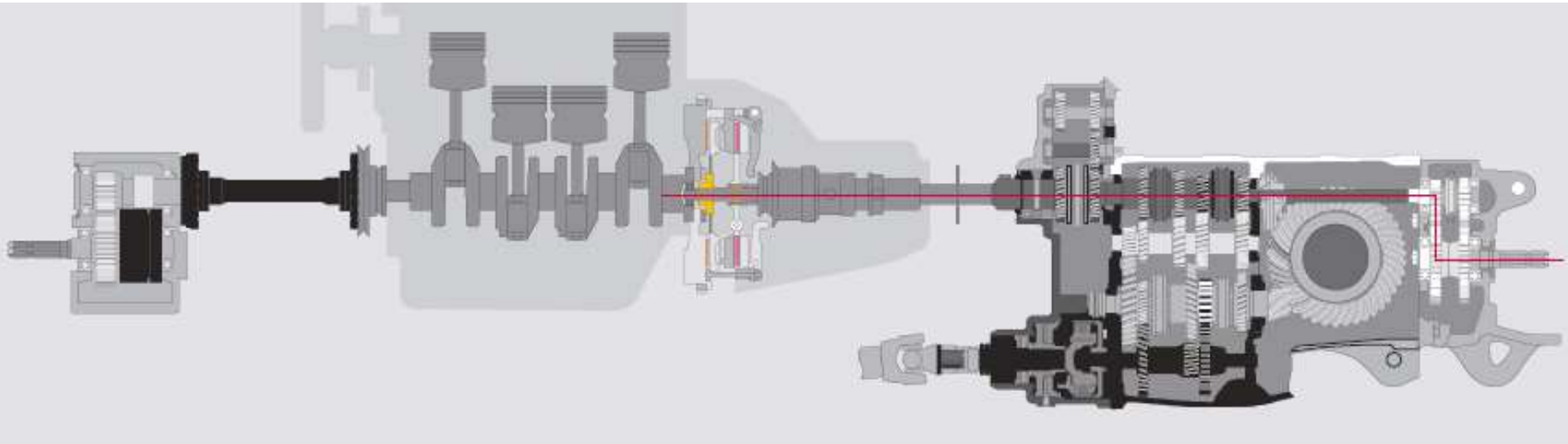

Stupnjevani mjenjač



Sheme mijenjanja brzina

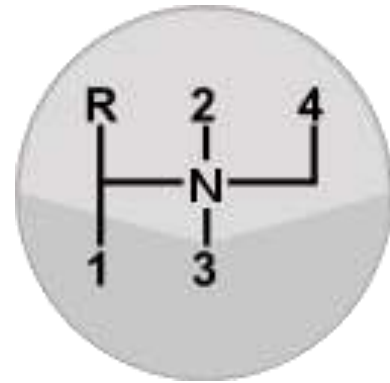
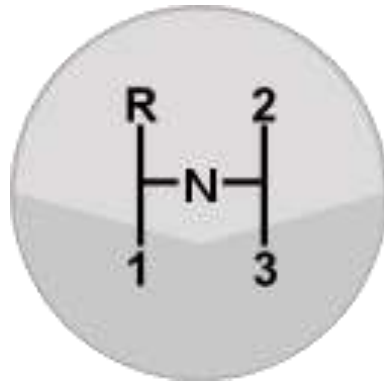
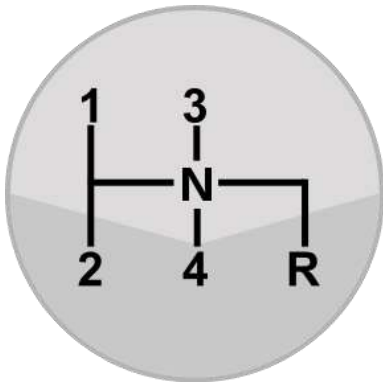

Mjenjač sa stalno uzubljenim zupčanicima

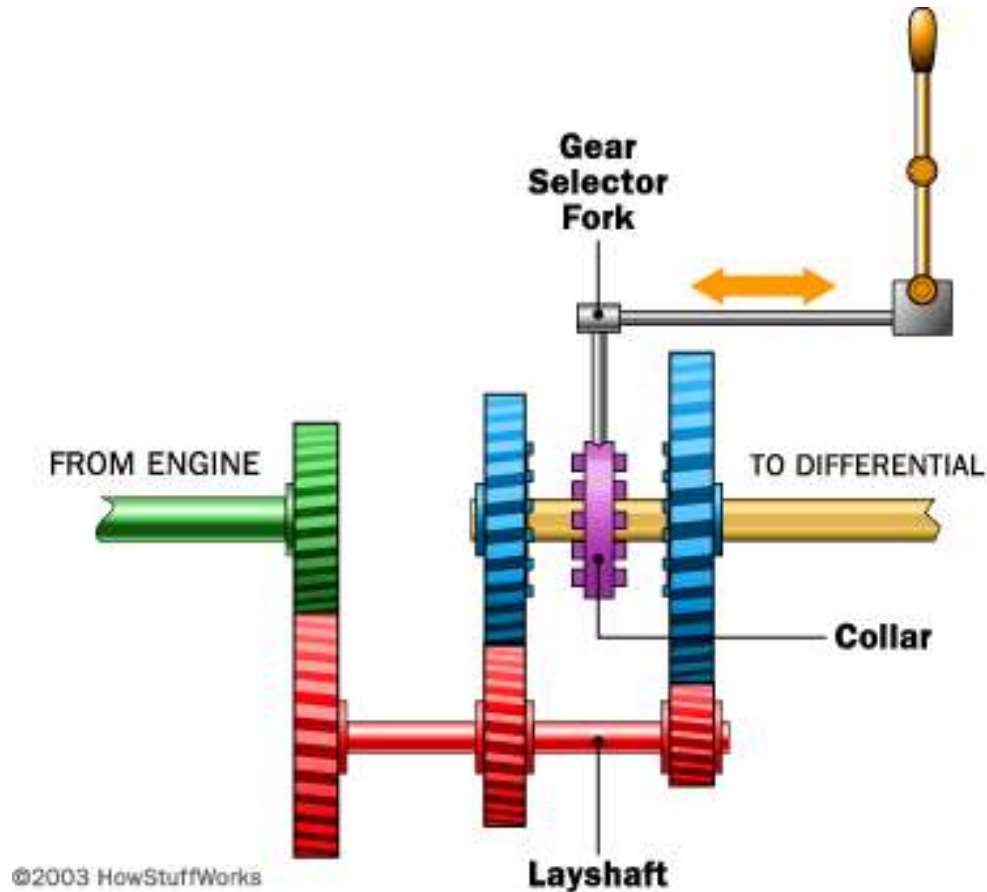

Sinhronizirani mjenjač s 4 stupnja prijenosa

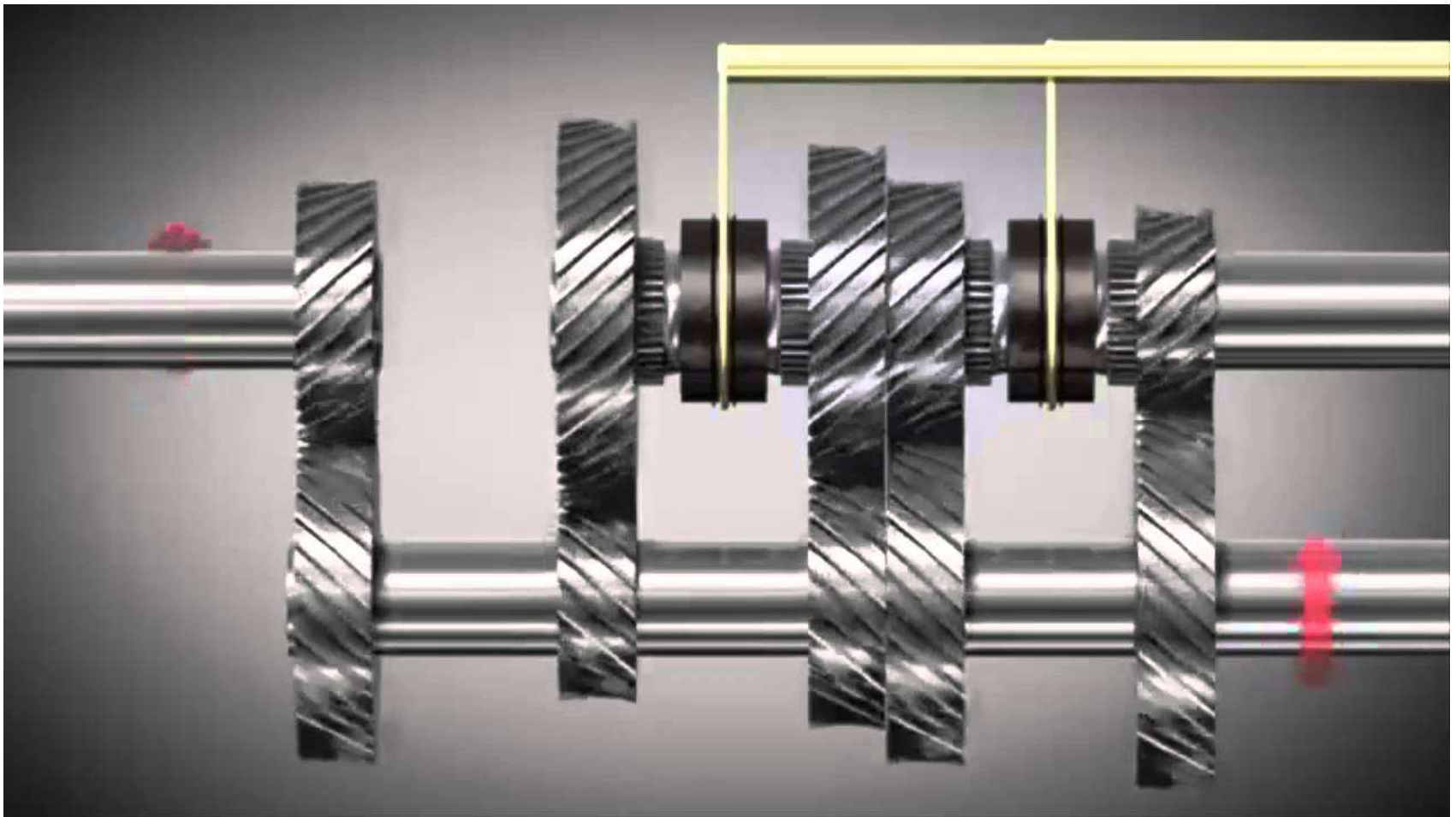

Prsteni za uključenje slobodnog zupčanika



Sinhroni mjenjača



Transmisija traktora JD 3350

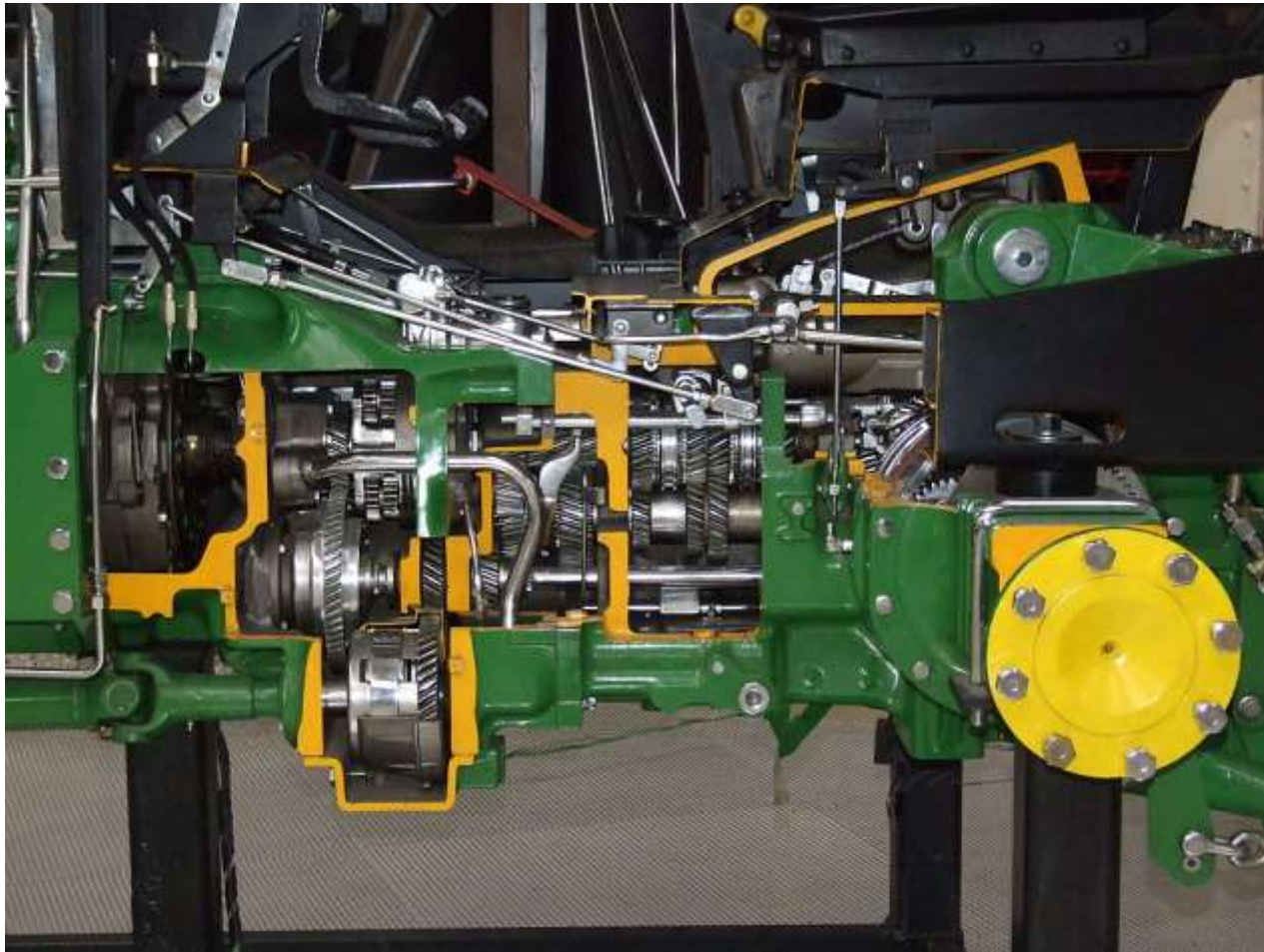

5-brzinski mjenjač

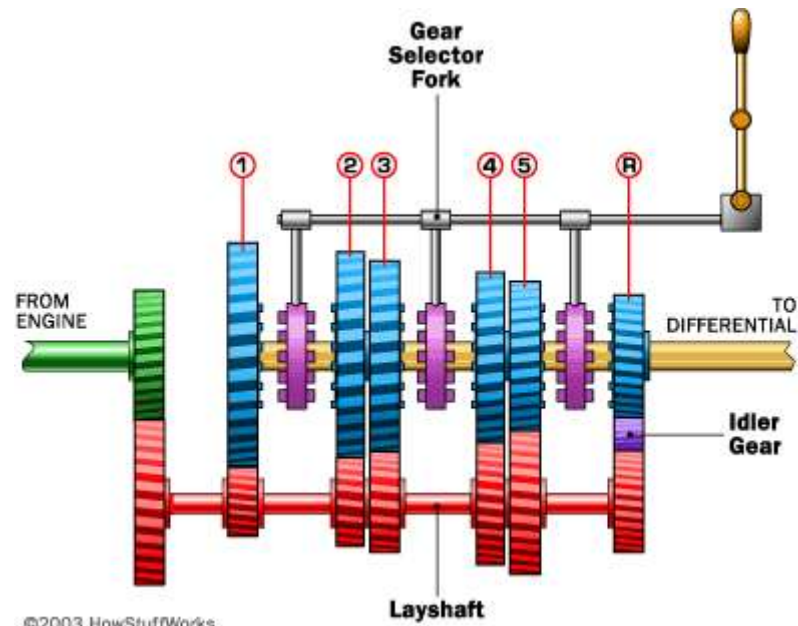

Međuzupčanik za kretanje u nazad

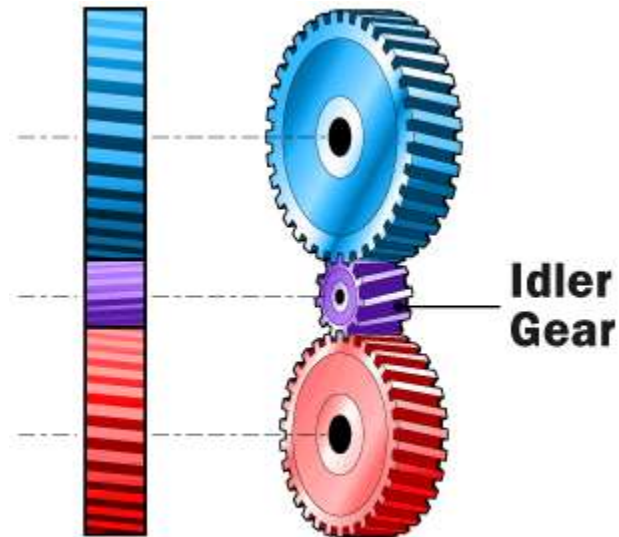

©2003 HowStuffWorks

Reduktor

Uloga:

Redukcija osnovnih (direktnih) stupnjeva brzina („zec – kornjača”)

Izvedbe:

Planetarni reduktor (na slici)

Reduktor s čeonim zupčanicima



Konusno-tanjurasti prijenosnik i diferencijal

Uloga:

KTP: promjena smjera pogona pod 90° i redukcija broja okretaja

DIF: Omogućava razliku obodnih brzina vanjskog i unutrašnjeg kotača u zavoju



Diferencijal



Uređaj za kočenje

Kočnice s bubnjem



Disk kočnice



Hidraulično aktiviranje kočnice glavni kočioni cilindar i radni cilindar

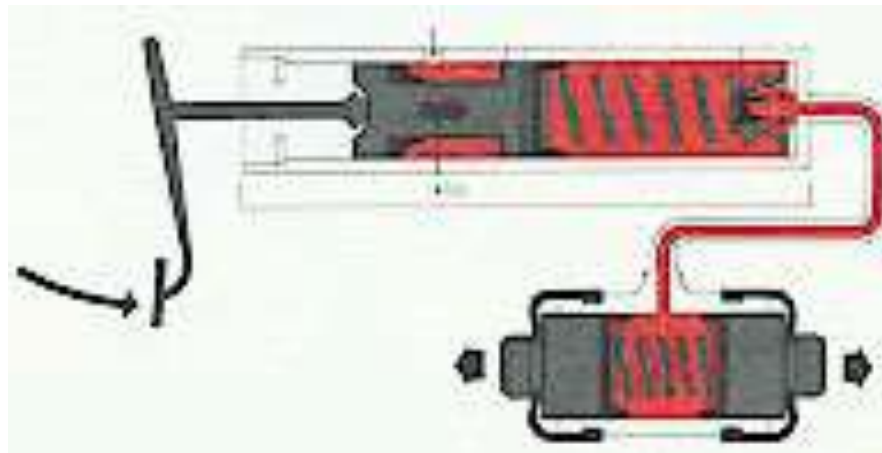

Ručna (parkirna) kočnica



Uređaj za upravljanje traktorom

- Mehaničko
 - S jednom uzdužnom sponom
 - S dvije uzdužne spone
 - Hidrauličko – preko upravljačkog cilindra
 - Preko centralnog zgloba – zglobni traktori

Upravljanje s jednom uzdužnom sponom

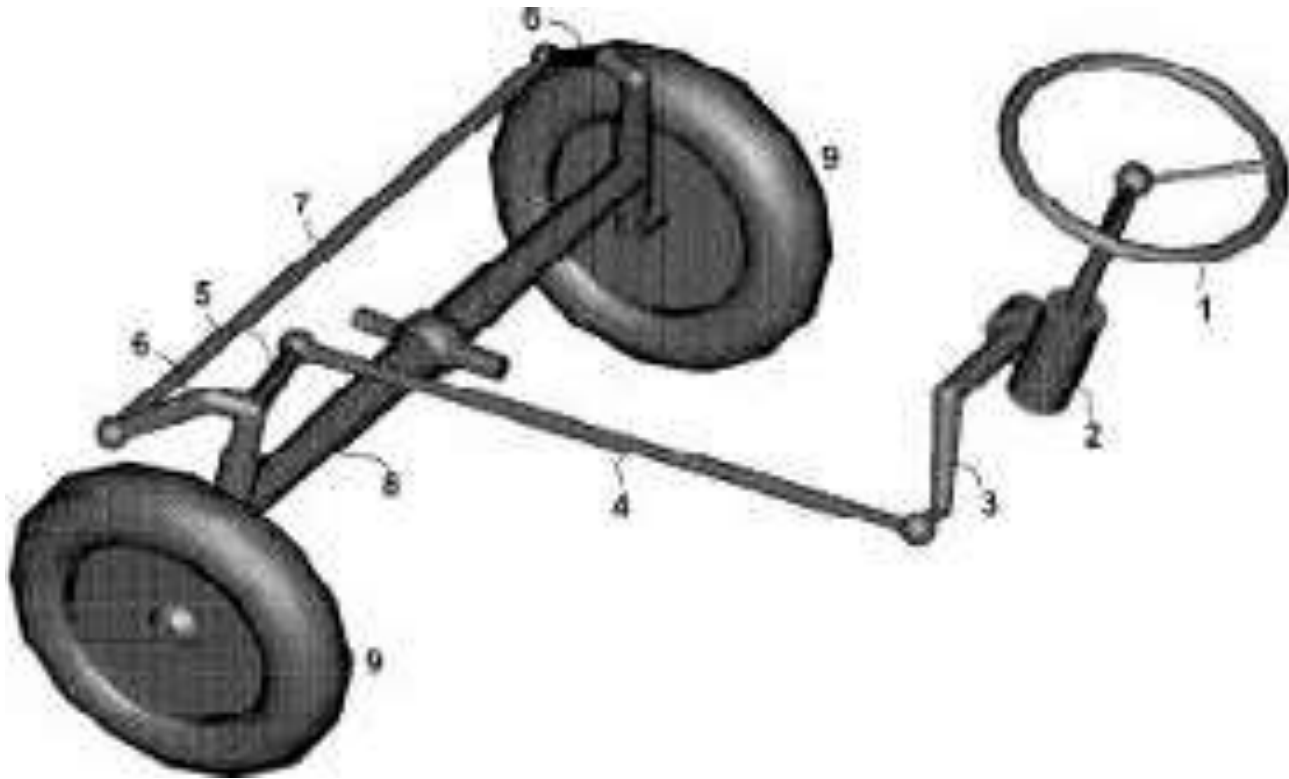

Mehanizam upravljača s konusnim i segmentnim zupčanicom



Hidrostatski upravljački mehanizam

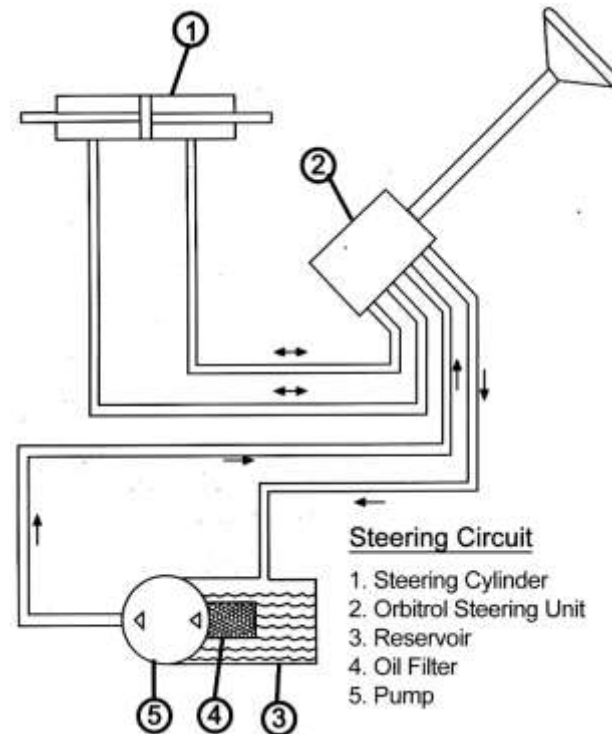

Hidrostatski upravljač



Upravljanje preko centralnog zgloba



Radijus okretanja kotača

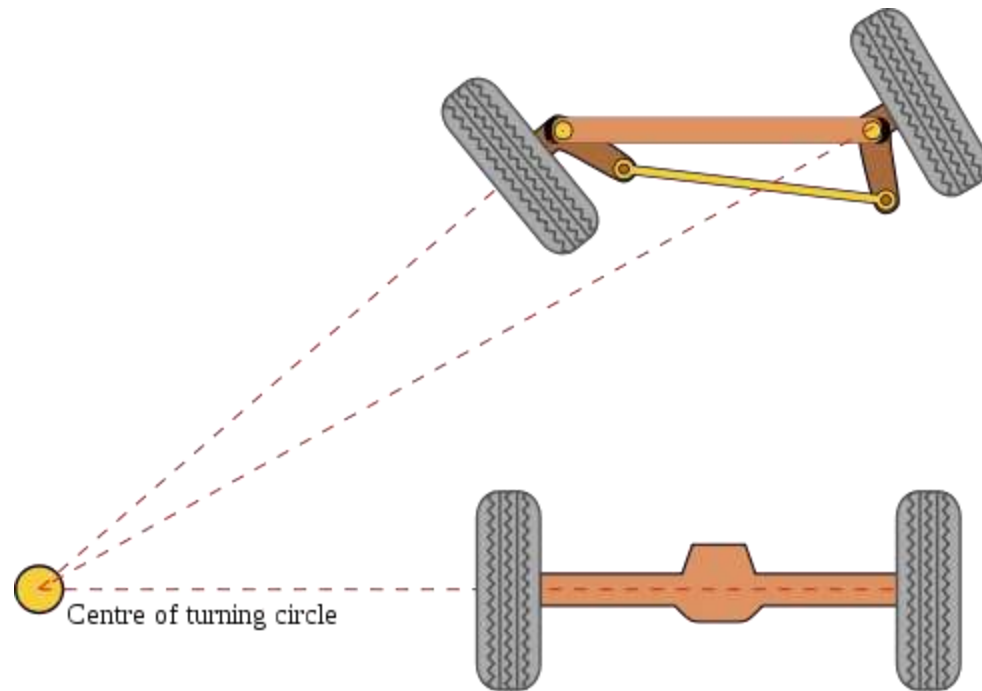

Uređaj za vožnju

- Traktori s pneumaticima
- Traktori gusjeničari
- Traktori s polugusjenicom

Traktor s pneumaticima



- Pneumatik
 - Naplatak
 - Disk
 - Vanjska guma
 - Unutrašnja guma (zračnica)
 - Ventil

Vanjska guma - presjek

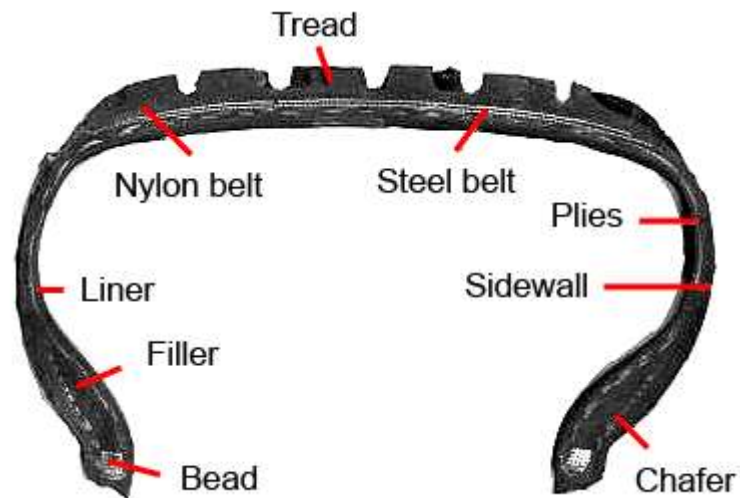
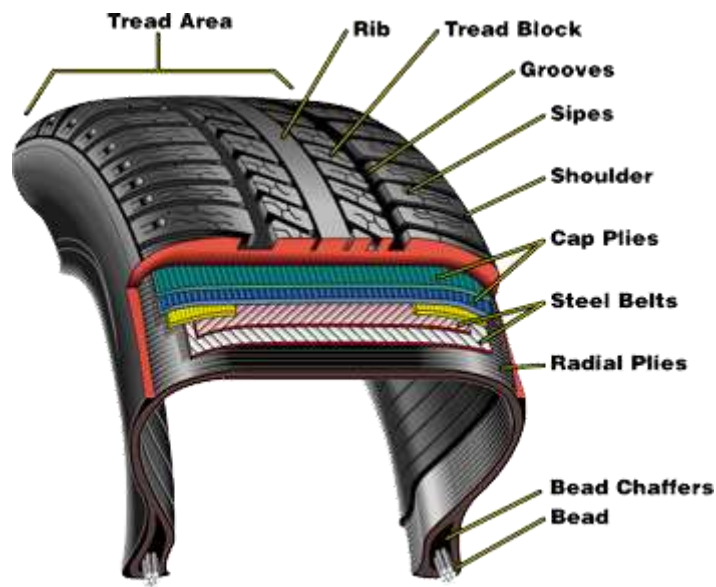

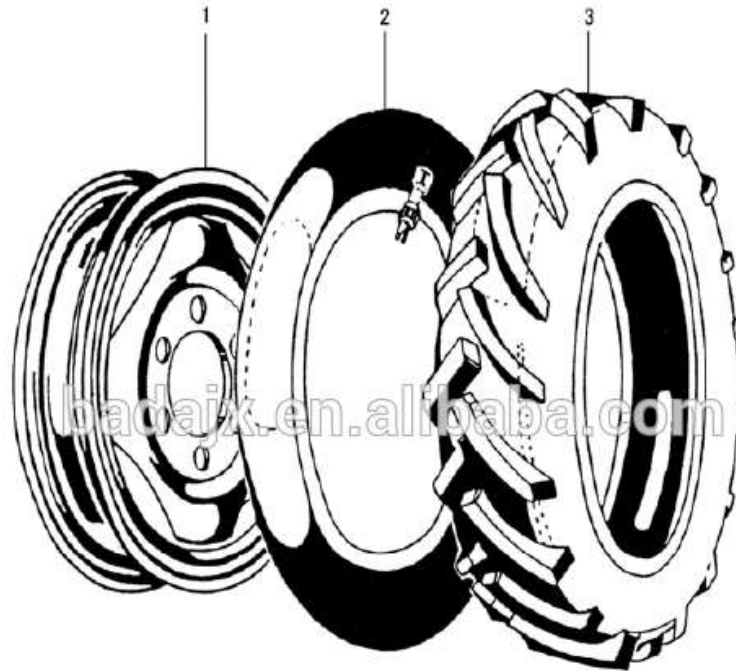

Front Driving Wheel (Four wheel drive)

Disk i naplatak



Kotači traktora

- Stražnji pogonski



- Prednji upravljački



Udvojeni kotači traktora



Rešetkasti kotači



Traktor gusjeničar



Mehanizam s gusjenicom



Traktori s gumenom gusjenicom



Traktor s 2 i 4 gusjenice



Traktor s 4 gusjenice



Pneumatik - dimenzije

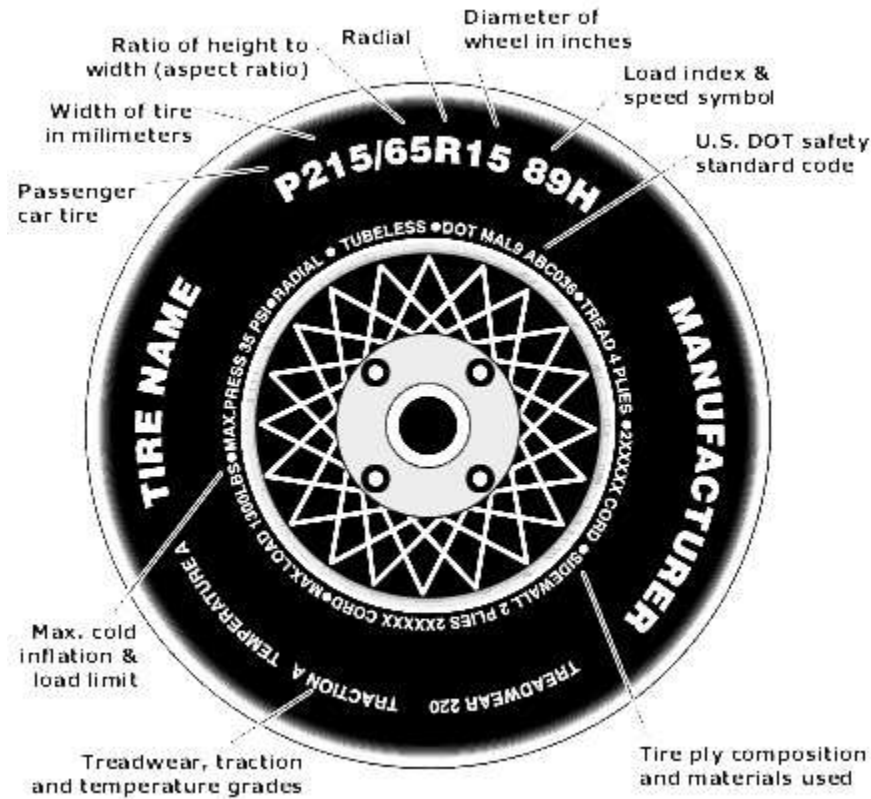

Električni uređaji na traktoru

El. generatori

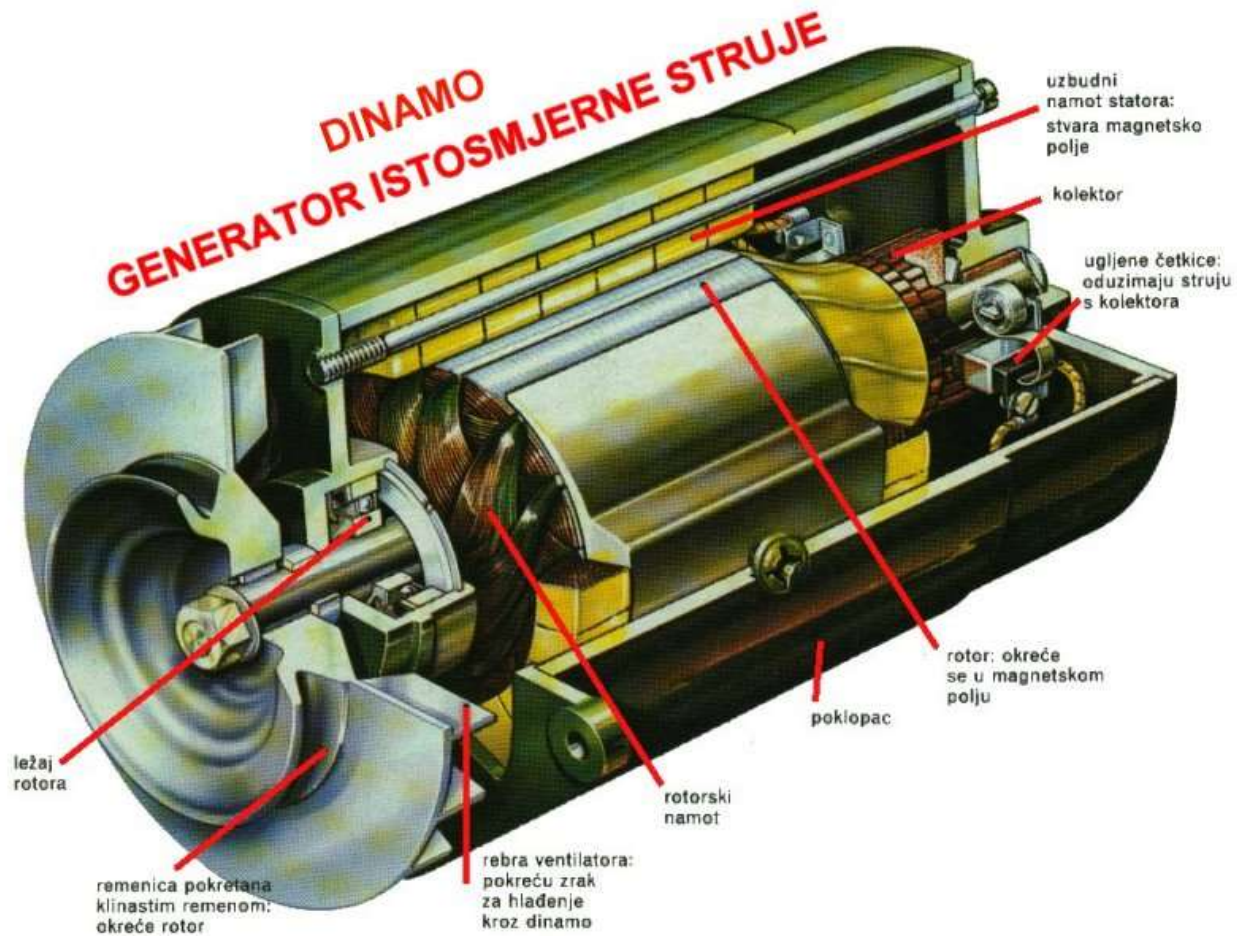

Regulator dinama (regler)

REGULATOR GENERATORA ISTOSMJERNE STRUJE

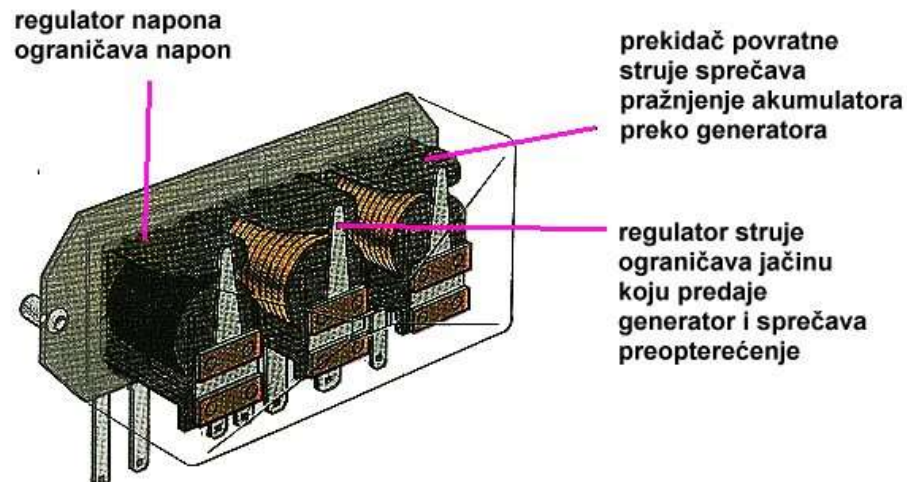

Alternator – generator izmjenične struje

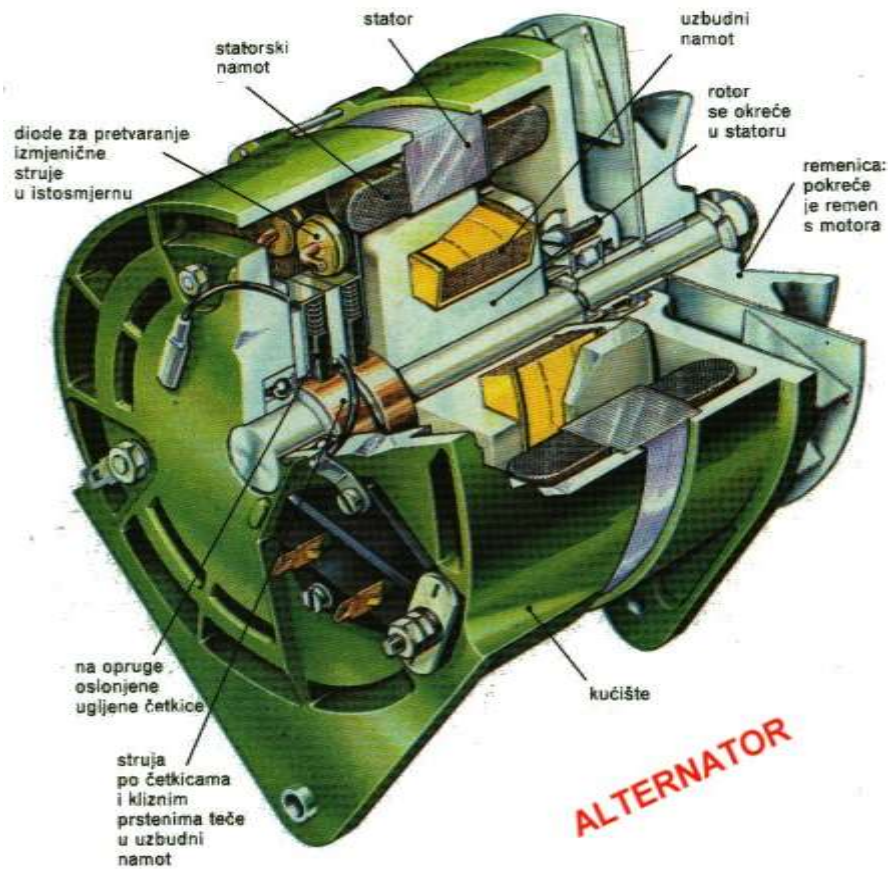

HIDRAULIČKI PODIZAČ TRAKTORA

- S JEDNOSTRANIM DJELOVANJEM
- S DVOSTRANIM DJELOVANJEM (rjeđe, na starijim istočno-europskim traktorima)

Hidraulički podizač s jednostranim podiznim cilindrom

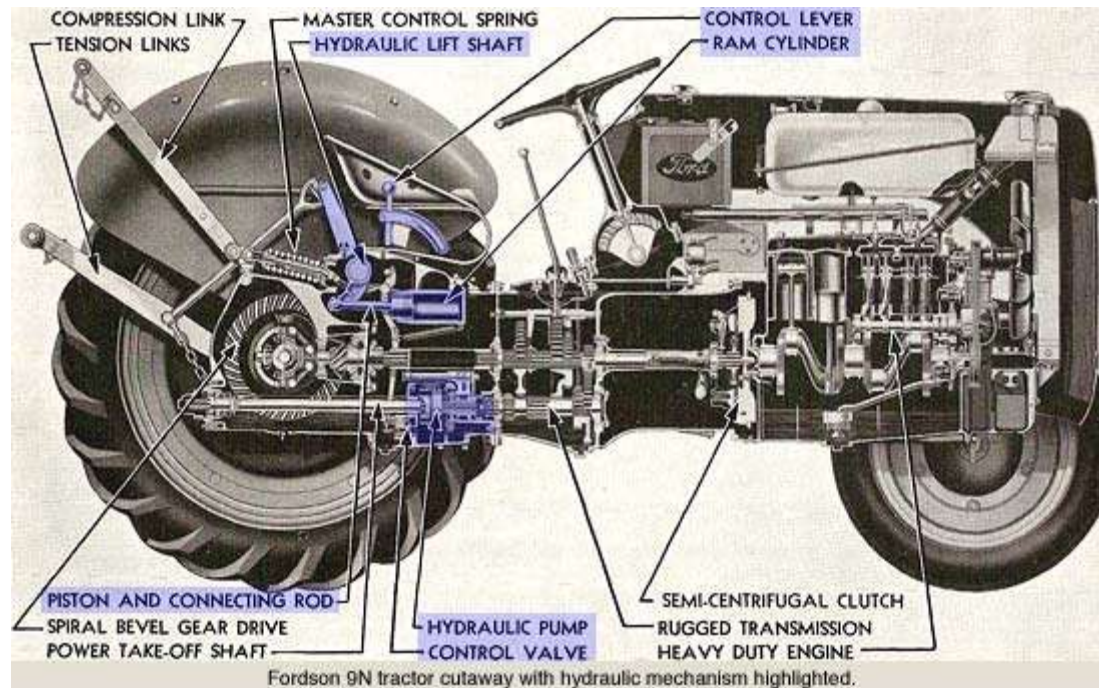

3-zglobna poteznica

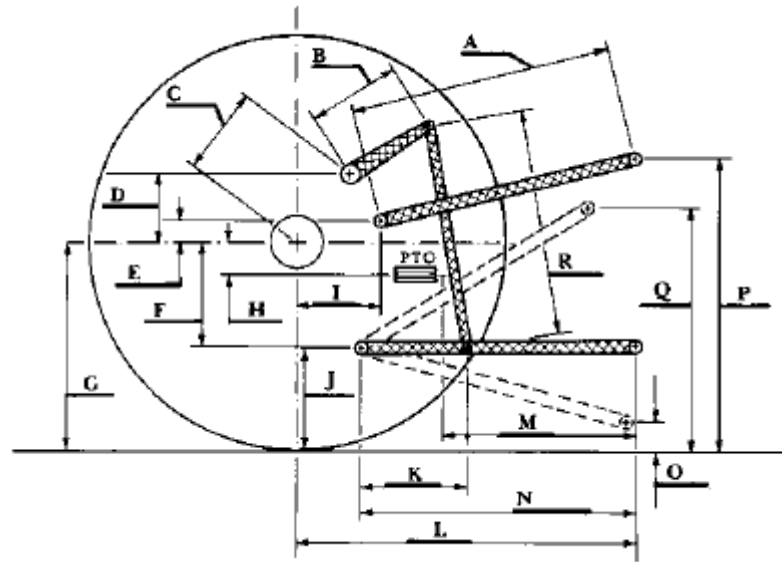

Kategorije 3-zglobne poteznice traktora

Kategorija	Snaga traktora KS	Promjer osovine upornice (in)	Promjer osovine hidrauličkog podizača (in)
0	< 20	5/8	5/8
1	20-45	3/4	7/8
2	40-100	1	1 1/8
3	80-225	1 1/4	1 7/16
4	180-400	1 3/4	2

- 3-zglobna poteznica



Dimenzije traktora Valtra serije A

Dimenzije

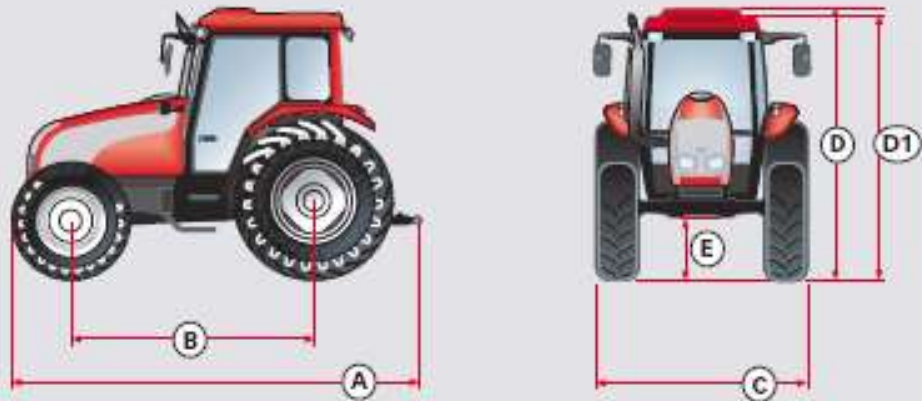

- A = Dužina
- B = Međuosovinski razmak
- C = Širina
- D/D1 = Visina do vrha krova
- E (4WD) = Klirens ispod prednje osovine

Modeli	A,mm	B,mm	C,mm	D,mm	E,mm
A72 4WD, 2WD	4056/3957	2387/2244	2137/2137	2655/2655	442
A82 4WD, 2WD	4056/3957	2387/2244	2175/2175	2680/2680	457
A92 4WD, /2WD	4056/3957	2387/2244	2175/2175	2680/2680	457

D1* 155 mm niže sa opcijom snižene kabine

Modeli	Gume Prednje/Stražnje
A72 4WD, 2WD	16.9R34/13.6R24, 16.9R34/10.00-16
A82 4WD, 2WD	16.9R34/13.6R24, 18.4R34/11.00-16
A92 4WD, 2WD	16.9R34/13.6R24, 18.4R34/11.00-16

Tehnička specifikacija traktora Valtra serije A

Model	A72	A82	A92
Motor	33DTA	44DTA	44DTA
Maks. snaga kw/ks/obr./min*	54/74/2270	65/88/2270	74,5/101/2270
Maks. moment sile Nm/obr./min*	296/1400	324/1400	360/1400
Broj cilindara	3	4	4
Kapacitet, ccm	3,3	4,4	4,4
Intercooler	da	da	da
Transmisija	Kompletno sinhronizirana		
Brzine naprijed/nazad	12+12R		
HiShift	Dodatna oprema		
Kardansko vratilo obr./min	540+540E / 540+1000		
Hidraulika	Odvojeno ulje hidraulike. Maks. količina ulja za vanjsku hidrauliku 24 l		
Maks. podizni kapacitet kN	28	33	33
Maks. podizna snaga sa dodatnim cilindrom, kN	33	-	-
Maksimalni kapacitet pumpe l/min	55	55	55
Volan	Hidrostatski. Namjestivi volan		
Kapacitet rezervoara	79 l +24 l dodatni rezervoar (dodatna oprema)		
Kočnice	Hidraulički mokri diskovi sa automatskim paljenjem pogona na sva četiri kotača kod kočenja sa sva četiri kotača		
Elektrika			
Starter	2,8 kW		
Alternator	95 Ah		
Akumulator	136 Ah		
Težina kg 4WD/2WD	3560/3330	3680/3450	3680/3450

*ISO 14396